

**REVIEW
ARTICLE****Hairy plant polysaccharides: a close shave with microbial esterases**

Gary Williamson, Paul A. Kroon and Craig B. Faulds

Author for correspondence: Gary Williamson. Tel: +44 1603 255259. Fax: +44 1603 507723.
e-mail: gary.williamson@bbsrc.ac.ukBiochemistry Department, Institute of Food Research, Norwich Research Park, Colney,
Norwich NR4 7UA, UK**Keywords:** plant cell wall, arabinoxylan, pectin, lignin, ferulic acid**Background**

Plants employ an impressive number of ingenious ways to protect themselves from disease. Probably the most important protection against invading micro-organisms is the erection of a tough physical barrier, the plant cell wall, which protects the delicate interior of the plant cell. Pore sizes in the plant cell wall are too small even to allow passage of viruses, and so microbes which infect by penetration must enter either through opportunistic breaks in the wall or by enzymic dissolution (Brett & Waldron, 1990). Plant-saprophytic and -pathogenic micro-organisms produce a range of enzymes to degrade plant cell walls in order to use the cell contents as nutrients or to digest and utilize the polysaccharides in the plant cell wall. This enzyme tool kit has evolved in some micro-organisms to unlock even the most recalcitrant plant cell walls, given time and suitable conditions.

Of the plant cell wall components, lignin is the most difficult to degrade and is found especially in more mature plant tissues, followed by cellulose, hemicellulose and pectins. The latter are particularly abundant in fruits, which are consequently much more susceptible to microbial attack. Lignin and plant polysaccharides are laid down in a complex but organized structure which resists enzymic attack by virtue of physical inaccessibility and chemical structure. The latter is augmented by the attachment of side chains, which in some polysaccharides are found on almost every monomeric unit. There are two types of side chain: substitutions to limit access of enzymes to the polysaccharide backbone, and cross-linkages between polysaccharides to increase the physical strength and integrity of the plant cell wall.

Hemicelluloses and pectins have a variety of side chains attached to a backbone. These include acetyl, methoxyl and feruloyl groups, all of which modify physical properties such as solubility and crystallinity of the polysaccharide (Hwang & Kokini, 1992) and reduce

accessibility of enzymes to the main chain (Mitchell *et al.*, 1990). Micro-organisms have evolved enzymes, in particular esterases, to remove these side chains and so allow access of their main-chain-degrading enzymes to the polysaccharide backbone.

One of the most important cross-linkages in plant cell walls is a linkage between two ferulic acid molecules on adjacent chains (Figs 1 and 2). During growth of shoots, as seen in *Avena sativa*, polysaccharides and lignin are laid down in the plant cell wall. Cessation of growth is correlated with covalent cross-linking of the plant cell wall by formation of diferuloyl linkages (ferulate dimers) between polymer chains (Kamisaka *et al.*, 1990). Ferulate dimers in wheat coleoptiles reduce plant cell wall extensibility (Wakabayashi *et al.*, 1997), and in oat, formation of dimers protects against pathogen invasion (Ikegawa *et al.*, 1996). Because of the dramatic increase in plant cell wall mechanical properties, this has been likened to 'spot welding of a steel mesh frame' (Iiyama *et al.*, 1994), which emphasizes the effects of these cross-links. Diferuloyl groups have been found in a wide variety of plants, but only recently have improvements in analytical techniques allowed accurate quantification and identification of these linkages (Ralph *et al.*, 1994; Waldron *et al.*, 1996). Recently, microbial esterases have been identified which can break some of these linkages, and clearly these will have a major impact on the structure and integrity of the plant cell wall (Bartolomé *et al.*, 1997).

This paper reviews the latest research on microbial esterases which 'shave' some of the side chains and break cross-links of plant polymers, and therefore play an important but underrated part in helping to provide nutrients for saprophytic and pathogenic micro-organisms. The enzymes hydrolysing these ester bonds which have so far been reported are cinnamoyl esterases, acylesterases and pectin methylesterases (Table 1). These enzymes are usually highly inducible, depending on the growth substrate, and are secreted by a wide range of bacteria and fungi.

Table 1. Classification of esterases which degrade plant cell walls based on the Enzyme Commission nomenclature

Enzyme Commission nomenclature	Subclass
Carboxylesterases (EC 3.1.1.1)	Cinnamoyl esterases: FAEA/FAE-III (feruloyl esterase) CinnAE (<i>p</i> -coumaroyl/cinnamoyl esterase) Cinnamoyl ester hydrolases
Acylesterases (EC 3.1.1.6)	Acetylxylan esterases Rhamnogalacturonan acylesterases Pectin acylesterases
Pectin methylesterase (EC 3.1.1.11)	Pectin methylesterase (pectinesterase)

Hemicellulose and pectin structure: why there are so many esterases

Rather than attempt a long description of the structure of these plant polymers, we have instead summarized the current view of their structures in Figs 1 and 2, which show the structure of a well-studied hemicellulose,

cereal heteroxylan, and rhamnified sugar beet pectin, respectively. Other types of hemicellulose such as β -glucans, xyloglucans and mannans are found in a wide variety of plants with a wide range of compositions. The ester linkages are indicated by arrows, and enzymes which act on many of the linkages have been described, characterized and sometimes cloned. Others have yet to

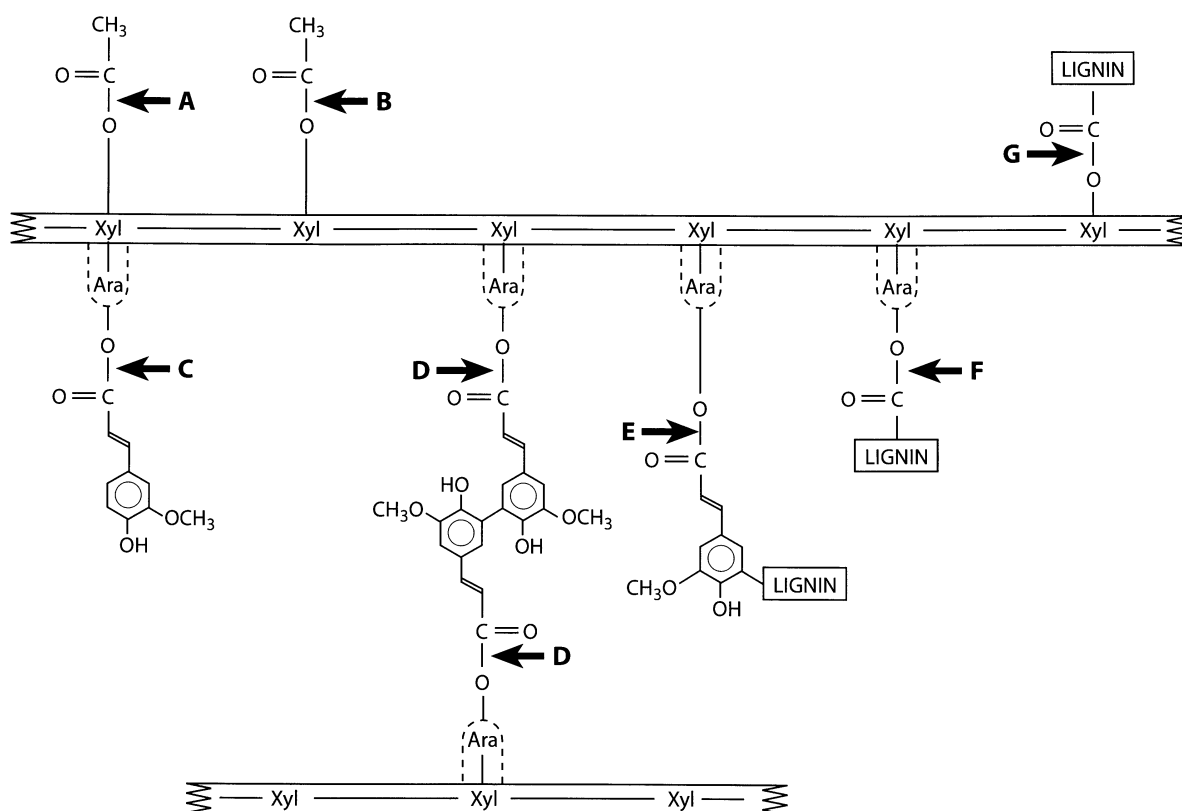

Fig. 1. Generalized and simplified structure of arabinoxylan, the main component of many hemicelluloses from primary cell walls of monocotyledonous plants. The 1,4- β -linked xylan backbone is indicated by parallel unbroken lines, and the sugar side chains are shown by broken lines. The ester bonds are shown by arrows as follows: (A) 2-O-acetyl group and (B) 3-O-acetyl groups, hydrolysed by xylan acylesterases; (C) 5-O-feruloyl group, hydrolysed by cinnamoyl esterases; (D) 5-O-diferuloyl groups (symmetrical molecules linking two polysaccharides); the dimer shown is the 5,5'-linked dimer, which is hydrolysed by ferulic acid esterases; other dimeric structures are common, which are not hydrolysed by ferulic acid esterases; (E) 5-O-feruloyl-lignin, and also 5-O-diferuloyl-lignin (not shown); (F) arabinose-lignin; (G) xylose-lignin. (E)–(G) are suggested structures, for which no esterases have yet been reported to hydrolyse.

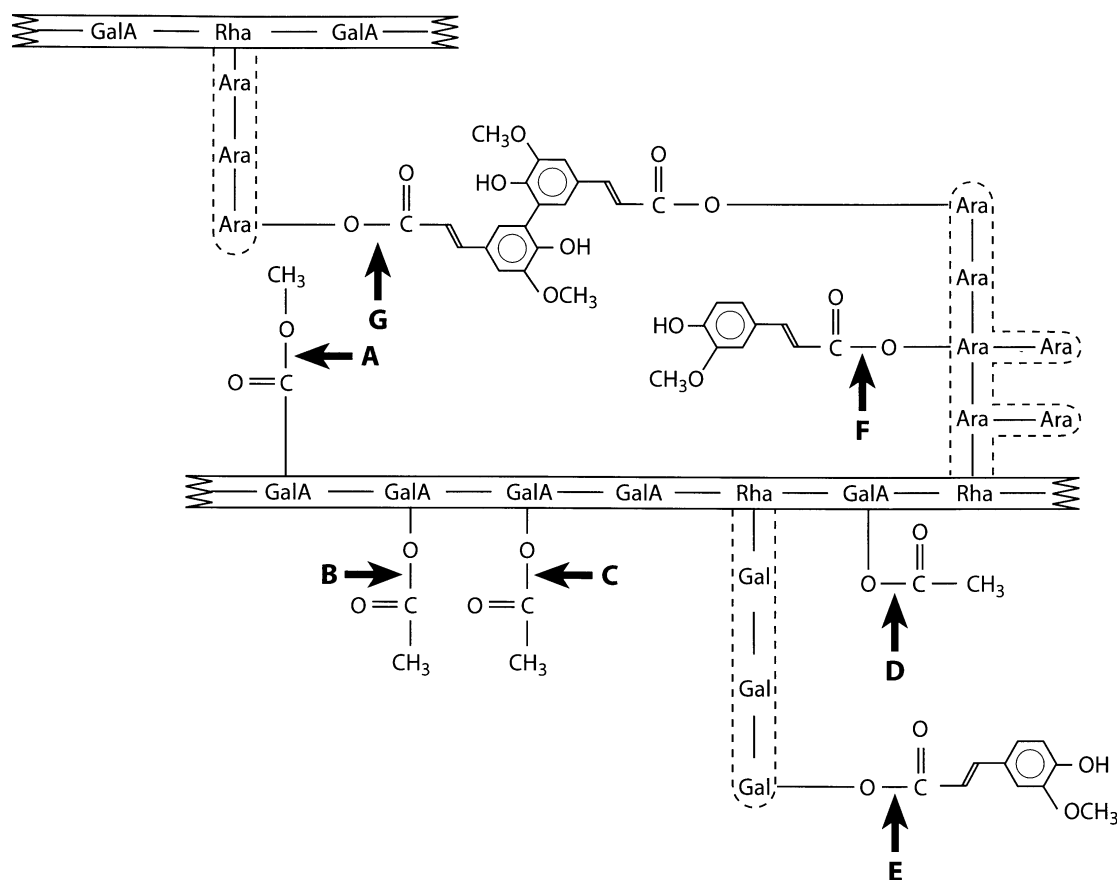

Fig. 2. Generalized and simplified structure of rhamnified pectin from sugar beet. The 1,4- α -linked galacturonic acid backbone in the 'smooth' regions is shown by parallel unbroken lines, and is only substituted with non-sugar substituents, which are (A) methyl esters on the carboxylic acid moiety (C-6) of galacturonic acid, hydrolysed by pectin methylesterase, and (B) 2-*O*-acetyl or (C) 3-*O*-acetyl groups, which are hydrolysed by pectin acetyesterase. The 'hairy' region of the backbone is alternating residues of galacturonic acid (GalA) and rhamnose (Rha), with substitutions on most of the residues; either (D) acetyl groups, hydrolysed by rhamnogalacturonan acetylerases, or sugar substituents (indicated by broken lines). These sugar side chains carry (E) feruloyl groups attached to C-6 of galactosyl residues or (F) feruloyl or (G) diferuloyl groups attached to C-2 of arabinose and hydrolysed by cinnamoyl esterases.

be found, especially those involving cross-linkages to lignin.

One surprise to us when we first started working in this area nearly 10 years ago was the necessity for more than one enzyme per organism to break all of these ester bonds. The esterase reaction is regarded as facile, and a number of general esterases have been described which at the time often had no known 'natural' function, but could hydrolyse laboratory substrates such as *p*-nitrophenyl acetate, triacetin and α -naphthyl acetate. One of the many problems with *p*-nitrophenyl acetate is that it spontaneously hydrolyses under most assay conditions, and weak catalysis is an activity of many proteins for which the normal function is not an esterase. Such 'general' esterases may have no activity on the more complex and less readily hydrolysed ester linkages in the plant cell wall.

Micro-organisms usually produce more than one esterase, which can be post-translationally modified, multi-copies of closely related genes or products of

unrelated genes. Historically, the nature of the hydrolysed linkage first described for an enzyme has defined the name (Table 1). Often enzymes have been purified, or partially purified, using substrate X and the results reported as an X esterase. In another laboratory, a different substrate is used (Y), but the same enzyme is purified, called a Y esterase, and so one enzyme is given two names. This is only resolved by cloning and sequencing or at least reporting of an N-terminal sequence. Because the field of plant-cell-wall-degrading esterases is no longer embryonic, we strongly recommend that all journals should only accept reports of novel plant-cell-wall-degrading esterases if accompanied by sequence data, with at least an N-terminal sequence. Studies on partially purified esterases should not be accepted. The currently accepted names for plant-cell-wall-degrading esterases are shown in Table 1, which also indicates the Enzyme Commission nomenclature. The distinction between enzymes is not always clear cut. Most of the enzymes listed will have some acetylerase activity on *p*-nitrophenyl acetate,

Table 2. Action of esterases on a 'class-specific' substrate (methyl ferulate) compared to a 'general' substrate (*p*-nitrophenyl acetate) gives an indication of the biological function of a plant-cell-wall-degrading esterase

The example here is for cinnamoyl esterases, and a higher ratio indicates a more 'specific' esterase. One unit is defined by the conversion of 1 μmol substrate min^{-1} at pH 6.0 in 0.1 M MOPS buffer at 30 °C.

Enzyme	Source	Activity (U mg^{-1}) on:		Ratio
		Methyl ferulate (1.0 mM)	<i>p</i> -Nitrophenyl acetate (1.0 mM)	
F AE-III	<i>Aspergillus niger</i>	85.0	118.0	0.72
CinnAE	<i>Aspergillus niger</i>	22.0	1.6	14.00
Esterase	<i>Pseudomonas fluorescens</i>	0.9	5.8	0.16

and this substrate can be used to determine selectivity of individual esterases despite its inherent instability by comparison to specific substrates. Table 2 illustrates this using cinnamoyl esterase activity as an example.

Esterases benefit micro-organisms, industry and biochemists

Micro-organisms

Some of the ester-linked substituents on plant cell wall polysaccharides retard or inhibit microbial infection; for example, adherence of *Agrobacterium* to plant tissues was sensitive to the degree of pectin methyl esterification (Rao *et al.*, 1982). This indicates that microbial esterases increase the chances of successful infection of a plant tissue by removal of the methoxyl side chains. There are many other examples in the literature, many of which concern the antimicrobial nature of the phenolics towards some micro-organisms. Phenolic components of the plant cell wall, especially *p*-coumaric acid and *p*-hydroxybenzaldehyde, inhibit the growth of rumen micro-organisms (Borneman *et al.*, 1986) and phenolic acids derived from plant cell walls have long been used as food preservatives to inhibit microbial growth (Davidson & Branen, 1981). *Magnaporthe grisea*, the rice blast fungus, produces a xylanase and an arabinofuranosidase which act synergistically to release arabinoxylo-oligosaccharides from rice cell walls. These compounds contain esterified ferulic acid, and their release leads to death (presumably programmed cell death) of surrounding rice cells. *In vitro* removal of the ferulic acid moiety (i.e. to give the phenolic and oligosaccharide separately) destroyed more than 95% of this killing ability (Kauffman *et al.*, 1990), which would enhance the chances of the colonization of the rice cell wall by the pathogen in the presence of a cinnamoyl esterase.

Microbial esterases also increase the rate at which main-chain-degrading enzymes hydrolyse the polysaccharide backbone, by removing groups which prevent access of the substrate to the active site by steric hindrance (see the section below on synergy with other enzymes).

Industry

One of the major bound phenolics in cereal cell walls is ester-linked ferulic acid. Certain micro-organisms utilize free ferulic acid and other phenolic compounds as carbon sources when sugars are scarce (e.g. Rahouti *et al.*, 1989). *Aspergillus niger* has recently been shown to transform ferulic acid to vanillic acid by propenoic chain degradation, leading to low yields of methoxyhydroquinone, and *Pycnoporus cinnabarinus* converts ferulic acid to vanillin, an essential flavour in the food industry (Lesage-Meessen *et al.*, 1996).

Pectins are traditionally used as gelling and thickening agents in a wide range of applications, and pectin acetyl esterase and pectin methyl esterases have been used to gel orange peel and sugar beet pectins (Williamson *et al.*, 1990). Pectin methyl esterases, free from depolymerases, are of special interest for preparing low-methoxy pectin gels (Ishii *et al.*, 1979) and for the clarification of ciders (Rombouts & Pilnik, 1986). In fruit juices, *A. niger* pectinases are added to reduce haze formation and precipitation, and pectinolytic enzymes, including esterases, are required for complete liquefaction (Whitaker, 1984).

Acetyl xylan esterase can be used in the de-inking of paper by aiding in the removal of substituent groups which will hinder main-chain-degrading enzymes. Esterases and lipases are also used in the degradation of vegetable-oil-based inks (Bajpai, 1997).

There are a large number of potential applications for these enzymes which have not yet been explored. Hemicellulases and cellulases offer alternatives to augment chemical and mechanical paper-pulping methods, and there is a large amount of literature on this subject (e.g. Tolan, 1996). Acetyl xylan esterases and feruloyl esterases may enhance this process by removing substitutions and linkages between polymers during pulping, thus making the solubilization of lignin-carbohydrate complexes easier (de Graaff *et al.*, 1992). After the removal of acetyl groups, the hemicelluloses crystallize and form more cellulose-like structures (Marchessault *et al.*, 1967) thus affecting polysaccharide

solubility and cohesiveness (York *et al.*, 1988). Ferulic acid is postulated to form cross-links with proteins in wheat (Hoseney & Faubion, 1981), which is important in the rheology of doughs, and so cinnamoyl esterases may play a role in the baking process. Pretreatment of lignocellulosic material by secreted fungal enzymes leads to de-esterification, which increased the rate of *in vitro* digestion by ruminal micro-organisms by about 80% (Akin *et al.*, 1993). Enzyme or microbial pretreatments of animal feeds will presumably increase hemicellulose digestibility *in situ*.

The (bio)chemist

Esterases have potential as analytical aids in modern carbohydrate chemistry. In combination with other plant-cell-wall-degrading enzymes, the esterases will provide important tools in understanding the fine structure and linkage patterns which exist in the plant cell wall, but the science is at an early stage and ripe for exploitation. Arabinoxylans and β -glucans in the cell walls of barley have been shown to be associated either together or to a common component via an ester bond, as shown by specific hydrolysis by a pure cinnamoyl esterase [FAE (ferulic acid esterase)-III] (Moore *et al.*, 1996). The exact nature of the covalent bond between lignin and carbohydrate polymers in the cell wall matrix of various plants has still to be determined, although evidence is beginning to accrue on these structures, and esterases could provide a useful tool in helping to determine this link.

Biochemical mechanisms – specificities, common motifs and catalysis

For well-characterized serine esterases such as acetylcholinesterase, lipases and serine proteases, catalysis involves two major elements, namely a nucleophilic serine and a general acid–base histidine. Catalysis occurs via an acylenzyme intermediate mechanism and usually involves a third (aspartic/glutamic acid) residue. Although plant-cell-wall-degrading esterases are less well characterized, the evidence available implies that many of the essential elements of catalysis are similar, suggesting that most plant-cell-wall-degrading esterases use a mechanism similar to other serine hydrolases. For example, modification of nucleophilic serine residues with phosphorylating agents has indicated a catalytic role for serine in cinnamoyl esterases (Kroon *et al.*, 1996) and acetylxylan esterases (Koseki *et al.*, 1997). Mutagenesis studies have indicated an important role for histidine in pectin methyl esterases (Duwe & Khanh, 1996). The mechanism of hydrolysis by pectin methyl esterases is different to that for cinnamoyl esterases and acylesterases since the products released from the enzyme active site are an alcohol (methanol) and a sugar carboxylic acid rather than a sugar alcohol and an acid as found for cinnamoyl esterases (phenolic acid) and acylesterases (acetic acid).

Further evidence that cinnamoyl esterases and acylesterases hydrolyse substrates using a mechanism similar

to the well-characterized serine hydrolases is provided by primary protein sequence alignments. Cinnamoyl esterase (FAEA) from *A. niger* and *Aspergillus tubingensis* (de Vries *et al.*, 1997) contains the GX SXG motif, a common conserved sequence in lipases (GHSLG); also, the number of amino acids and their predicted secondary structure between the putative active site serine, histidine and aspartic acid residues is similar to the lipases of *Rhizopus delemar*, *Rhizomucor miehei*, *Humicola lanuginosa* and *Penicillium camembertii*. There are also examples where plant-cell-wall-degrading esterases (e.g. *Erwinia chrysanthemi* pectin acylesterase and a rhamnogalacturonan acylesterase from *Aspergillus aculeatus*) do not contain the GX SXG motif typical of certain lipases (Shevchik & Hugouvieux-Cotte-Pattat, 1997; Kauppinen *et al.*, 1995). *Aspergillus* pectin methyl esterase does not contain the GX SXG motif (Christgau *et al.*, 1996) but contains an active site histidine (Duwe & Khanh, 1996) and possibly a tyrosine (Markovic *et al.*, 1996).

Substrate specificity and kinetics

It is extremely common for esterases to be active on a broad range of substrates. Specificity, as defined by the rate of catalysis divided by the Michaelis constant (k_{cat}/K_m), gives the best indication of ‘preferred’ substrates. However, hydrolysis of polymeric substrates is more complicated since not all of the esterified substituents are chemically equal, and effects such as decreased solubility and steric hindrance further complicate any results obtained; these data should not be extrapolated to obtain kinetic constants.

Although esterases acting on plant cell walls catalyse a similar chemical reaction, they work on remarkably different substrates, and their specificity will be defined mainly by recognition of molecular structures adjacent to the ester bond. There is, however, no evidence to date indicating that any of the esterases covered by this review have specific subsites able to bind sugars: sugar subsites are found in most enzymes active on polysaccharide main chains (Pitson *et al.*, 1997). However, some esterases are modular in structure and contain domains designed to recognize and bind to polymers such as cellulose and xylan (see below).

The range of substrates used to characterize plant-cell-wall-degrading esterases is diverse, including both natural and synthetic esters. They range in size and complexity from small, soluble esters such as feruloylated oligosaccharides isolated from plant cell walls and phenolic acid methyl esters for cinnamoyl esterases and acetylated methyl glycosides and triacetin for acetylxylan esterases/pectin acylesterases, to larger, more complex and often less soluble substrates such as feruloylated, polymeric plant cell wall fractions for cinnamoyl esterases, acetylated xylans for acetylxylan esterases, acetylated pectins for pectin acylesterases and rhamnogalacturonan acylesterases, and methyl esterified pectins for pectin methyl esterases. The use of small, soluble substrates allows the determination of

kinetic constants, giving some information on the affinity (from K_m values) and catalytic efficiency (V_{max}/K_m), which is probably the best measure of specificity. The apparent affinities (K_m) for two cinnamoyl esterases varied by two orders of magnitude depending on the substrate: *A. niger* FAEA/FAE-III exhibited a low K_m for ferulic acid esterified to sugars {e.g. $K_m = 6 \times 10^{-6}$ M for *O*-[5-*O*-(*trans*-feruloyl)- α -L-arabinofuranosyl]-(1 \rightarrow 3)-*O*- β -D-xylopyranosyl-(1 \rightarrow 4)-D-xylopyranose (ferulic acid esterified to arabinose, which is then linked by glycosidic bonds to two xylose residues)} but much higher values when the ferulic acid is methyl esterified ($K_m = 720 \times 10^{-6}$ M; Kroon *et al.*, 1997). This may reflect differences in recognition of the substrate (i.e. specific binding site for sugar), or may be due to differences in chemical characteristics of the part of the substrate which is esterified to the carboxyl group (the first leaving group). The substrate requirements for cinnamoyl esterases have been examined. Large differences in K_m and V_{max} for *A. niger* cinnamoyl esterases were effected by (1) changes in the type of substitutions on the benzene ring, (2) changes in the number of substitutions on the benzene ring, (3) changes in the distance between the ester bond and the benzene ring, (4) changing the aliphatic from saturated to unsaturated and (5) changes in the number of sugar residues (Kroon *et al.*, 1997).

Substrate specificity can be used to group some enzymes; for example, some esterases are active only on small, soluble oligomeric substrates while others also show good activity on polymeric substrates. Cinnamoyl esterases can be grouped into those working on feruloyl-sugar esters (feruloyl esterases) and those working on *p*-coumaroyl-sugar esters (*p*-coumaroyl esterases), although there are examples of isolated enzymes possessing both activities (Borneman *et al.*, 1990a, 1992; Castanares *et al.*, 1992; Donaghy & McKay, 1997). Cinnamoyl esterases can be distinguished depending on whether they have a higher activity on substrates containing ferulic acid ester linked to the C-2 of arabinofuranose (e.g. *A. niger* CinnAE; Kroon & Williamson, 1996), or whether the highest activity is on ferulic acid linked to C-5 of arabinofuranose (e.g. *A. niger* FAE-III; Ralet *et al.*, 1994). Acetylerases are (in general) specific for deacetylation of only one type of polysaccharide (Searle-van Leeuwen *et al.*, 1992). They are categorized according to preference for acetylated xylo-oligomers or polymeric acetylxytan (Kormelink *et al.*, 1993). Distinction between acetylerases and acetylxytan esterases has been made by some (Johnson *et al.*, 1988) although others believe the same group of proteins is responsible (Bachman & McCarthy, 1991).

Specificity of acetylerases for the substitution position on the main chain

Xylose residues in xylan and polygalacturonic acid residues in pectin are acetylated either at the 2 position, 3 position or both. There is evidence to show that some acetylerases distinguish between these positions. The acetylxytan esterase of *Trichoderma reesei* preferentially

removes acetyl groups from positions 2 and 3 of acetylated methyl glycosides, with the rate increased by an order of magnitude (compared to diacetylated substrates) for 2- or 3-monoacetylated xylo-/gluco-/mannopyranosyl substrates (Biely *et al.*, 1997). Hence the specificity demonstrated by acetylxytan esterases is highest with naturally occurring acetyl substitutions present *in muro*. The *Schizophyllum commune* acetylxytan esterase preferentially deacetylated the 3 position of acetylated xylopyranosides and was also active on gluco- and mannopyranosyl substrates, leading Biely and co-workers to suggest the enzyme was a general polysaccharide deacetylase (Biely *et al.*, 1996). *Streptomyces lividans* acetylxytan esterase did not hydrolyse acetylated mannopyranosyl residues but worked at positions 2 and 3 of acetylated xylopyranosides almost simultaneously (Biely *et al.*, 1996, 1997), in contrast to the *T. reesei* enzyme, which worked more sequentially. Deacetylation of 2- and 3-monoacetylated xylopyranosides may involve an enzyme-catalysed formation of a five-membered transition state from which the acetyl group is released (such intermediates may be formed when acetyl groups migrate around the sugar ring). Acetylxytan esterases demonstrate different regio-selectivity for deacetylation of methyl glycosides when compared to lipases used for carbohydrate deacetylation (see Biely *et al.*, 1997). Searle-van Leeuwen *et al.* (1992) demonstrated that *A. niger* pectin acetylerase removed only one type of acetyl group out of the two possible on the polygalacturonic acid chain (position 2 or 3), but were unable to show which position was hydrolysed.

Synergy with main-chain-degrading enzymes

In general, plant-cell-wall-degrading esterases demonstrate strong synergistic relationships with endo-acting main-chain-degrading enzymes such as xylanases, arabinanases, galactanases, mannanases, polygalacturonases and rhamnogalacturonases. In many cases, the synergy is of a reciprocal nature, where the action of either enzyme enhances the action of the other. Some pectin methylesterases, such as those from *Aspergillus* spp., act by a multi-chain mechanism removing methoxy groups at random (Ishii *et al.*, 1979), in contrast to plant pectin methylesterases (e.g. isolated from tomato or orange peels), which act preferentially either at the non-reducing end or next to a free carbonyl group and proceed along the molecule by a single-chain mechanism (Kohn *et al.*, 1983). Polygalacturonase and pectin lyase are unable to degrade highly methyl esterified pectins, and their activity in depolymerizing pectins is greatly increased in the presence of pectin methylesterase activity.

Acetylxytan esterase activity increases the rate of hydrolysis of xylan by xylanases (Biely *et al.*, 1986). The extent of the synergy depends on the degree of acetylation (Ross *et al.*, 1992). Sequential attack on acetylated xylans by acetylxytan esterase/xylanase in different orders influences (1) the extent of hydrolysis and (2) the uniformity of fragments released from 4-*O*-methyl-

glucuronoxylan (Puls *et al.*, 1991). The *T. reesei* enzyme released most, but not all, of the acetyl groups from polymeric beechwood *O*-acetylglucuronoxylan. It was proposed that the remaining acetyl groups were adjacent to 4-*O*-methylglucuronosyl substituents and hence their action was precluded by steric hindrance, or the enzyme was able to remove acetic acid from only one position on the xylose ring (Poutanen *et al.*, 1990). Efficient removal of acetyl substitutions from polymeric acetylxyylan renders the xylan insoluble (Poutanen *et al.*, 1990).

A. niger cinnamoyl esterases release free ferulic acid from arabinoxylans (Faulds & Williamson, 1994) and pectins (Kroon *et al.*, 1996). Both the rate and efficiency of release are enhanced by an order of magnitude in the presence of main-chain-cleaving enzymes (Faulds & Williamson, 1995; Kroon & Williamson, 1996). The action of the esterase also enhances the action of the main-chain endo-hydrolase (Bartolomé *et al.*, 1995).

Sequence similarities and structural families

The number of sequences published by the end of 1997 for microbial cell-wall-degrading esterases is as follows: cinnamoyl esterases, four; acetylxyylan esterases, eleven; pectin methylesterases, four; pectin acetylerases, two. However, even though there are over 20 different gene sequences encoding esterases involved in degradation of plant cell walls, the derived protein sequences do not appear to be very highly conserved, even when the functionalities appear the same (e.g. within the acetylxyylan esterases) (Table 3). There are short sequences of conserved motifs, such as the GX SXG sequence for many lipases and esterases described above. It is also likely that secondary structure predictions and hydrophobic cluster analysis will provide more information on relationships between esterases. Currently, grouping them into families is not yet possible, in contrast to other enzymes involved in degradation of cell walls, such as xylanases, which divide nicely into two families (family 10 and family 11). For example, acetylxyylan esterases from distinct species are generally not similar to each other (Lüthi *et al.*, 1990; Ferreira *et al.*, 1993; Shareck *et al.*, 1995; de Graaff *et al.*, 1992; Margolles-Clark *et al.*, 1996; Koseki *et al.*, 1997; Dalrymple *et al.*, 1997; Lorenz & Wiegel, 1997; Laurie *et al.*, 1997; Tsujibo *et al.*, 1997), although there was high identity between the *Streptomyces* enzymes and the NodB-like domain from *Cellulomonas fimi* which functions as a deacetylase (Tsujibo *et al.*, 1997; Laurie *et al.*, 1997). Some identity was found between acetylxyylan esterases, the rhizobial NodB protein, the chitin deacetylase (Cda) of *Rhizomucor rouxii*, fungal cutinases, and regions near the active site of some lipases (Shareck *et al.*, 1995; Margolles-Clark *et al.*, 1996; Laurie *et al.*, 1997; Dalrymple *et al.*, 1997). These types of data lead the authors to speculate that the function reported for many of these proteins is not necessarily their primary function. To identify the true function of a protein, and in order to form groups with other related proteins, account needs to be taken of the following in addition to the enzyme activity: sequence identity/similarity with

other proteins, similarity in secondary structure, the function of the operon it is located within (bacteria), linking of transcription with other genes, and the functions of all domains which may be part of the full-length protein. However, with the area of cell-wall-degrading enzymes generating so much interest over the last 5–10 years, and with recombinant DNA techniques continuing to advance, the authors believe the number of primary sequences and secondary structures will rise rapidly over the next 3–5 years. This should allow better identification of primary functionalities, organization into discrete families, and perhaps indicate ancestral origins for many of these proteins.

Modular structure

In many reports detailing searches for sequence identity with esterases, identity is demonstrated between regions of the newly sequenced protein and either known domains whose function is to bind to polymeric substrates, or domains of unknown function. For example, there is a strong identity between one of the domains in the acetylxyylan esterases of *Pseudomonas fluorescens* subsp. *cellulosa* and *T. reesei* and known bacterial cellulose-binding domains (Ferreira *et al.*, 1993; Margolles-Clark *et al.*, 1996). The binding domain is separated from the catalytic domain by a linker region; truncated enzymes containing only the catalytic domain are fully active on soluble substrates but lose the ability to bind cellulose. Similarly, sequence analysis of a multidomain protein from *C. fimi* which hydrolyses acetyl groups from acetylxyylan indicated the presence of both a cellulose-binding domain and a xylan-binding domain (Laurie *et al.*, 1997). The acetylxyylan esterase of *Str. lividans* comprises a catalytic domain and a xylan-binding domain separated by a glycine-rich linker region (Shareck *et al.*, 1995). However, although it has been demonstrated that these domains facilitate binding to specific polymeric substrates, there are no reports describing how this affects the mode of action in hydrolysis of large polymers such as acetylated xylans. Since the most likely role for the binding domains is to mediate substrate recognition and binding (Coughlan & Hazlewood, 1993), then we predict that hydrolysis of polymeric substrates by modular enzymes containing binding domains is not random, but rather is focused in discrete areas of the polymer defined by the initial point of binding.

Crystal structures

To date, there are no refined crystal structures for esterases covered in this review. The only crystals reported in the literature are those for a *Penicillium purpurogenum* acetylxyylan esterase (Pangborn *et al.*, 1996). Although the space group ($P2_12_12_1$) and cell dimensions ($a = 34.9 \text{ \AA}$, $b = 61.0 \text{ \AA}$, $c = 72.5 \text{ \AA}$; $1 \text{ \AA} = 0.1 \text{ nm}$) were reported, the refined crystal structure has yet to be published. This is a serious limitation and precludes correlation of catalytic properties with secondary structure and complete delineation of the catalytic mechanism for these esterases.

Table 3. Possible relationships between plant-cell-wall-degrading esterases

The authors are highly sceptical of drawing conclusions from relationships identified between plant-cell-wall-degrading esterases at this stage. In this table, we identify possible distant relationships as they are suggested in the given citations. In general, for proteins where a similar functionality is reported (e.g. acetylxylan esterase activity), the identity and similarity are high (> 85 %) for those from different species but within the same genera, but relatively low (< 30 %) for those from different genera. AXE, acetylxylan esterase; CEH, cinnamoyl esterase; PME, pectin methyl-esterase; PAE, pectin acetyl-esterase; RGAE, rhamnogalacturonan acetyl-esterase.

Gene	Enzyme	Genus and species	Putative active site sequence*	Putative related proteins	Reference
<i>stx-III</i>	AXE	<i>Streptomyces thermoviolaceus</i>	Not identified	AXE of <i>Streptomyces lividans</i> , NodB-like domain from <i>Cellulomonas fimi</i> xylanase D, nodulation proteins from <i>Rhizobium</i> sp., chitin deacetylase of <i>Rhizomucor rouxii</i> and a polysaccharide deacetylase of <i>Bacillus stearothermophilus</i>	Tsujiibo <i>et al.</i> (1997), Laurie <i>et al.</i> (1997), Shareck <i>et al.</i> (1995)
<i>cinA</i>	CEH	<i>Butyrivibrio fibrisolvens</i>	GH <u>S</u> QG	AXE from <i>Caldocellum saccharolyticum</i> , an AXE (XylD) from <i>Pseudomonas fluorescens</i> subsp. <i>cellulosa</i> , N-terminal domain of unknown function from XynZ xylanase of <i>Clostridium thermocellum</i>	Dalrymple <i>et al.</i> (1996), Dalrymple & Swadling (1997)
<i>cinB</i>	CEH	<i>Butyrivibrio fibrisolvens</i>	GG <u>S</u> QG		
<i>axe1</i>	AXE	<i>Trichoderma reesei</i>	GY <u>S</u> QG	Fungal cutinases and <i>Penicillium purpurogenum</i> AXE-II	Margolles-Clark <i>et al.</i> (1996)
<i>xylD</i>	AXE/CEH	<i>Pseudomonas fluorescens</i>	Not identified	CinA and CinB of <i>Butyrivibrio fibrisolvens</i> and related proteins (see above)	Ferreira <i>et al.</i> (1993)
<i>pme1</i>	PME	<i>Aspergillus aculeatus</i>	CGQACHQALA	PMEs of tomato, <i>Erwinia</i> and <i>Pseudomonas solanacearum</i>	Christgau <i>et al.</i> (1996)
<i>pmeA</i>	PME	<i>Aspergillus niger</i>	CGQACHQALA		
<i>paeY</i>	PAE	<i>Erwinia chrysanthemi</i>	Not identified	RGAE of <i>Aspergillus aculeatus</i>	Shevchik & Hugouvieux-Cotte-Pattat (1997)
<i>bnA/bnA</i>	AXE	<i>Neocallimastix patriciarum</i>	GD <u>S</u> IT	RGAE of <i>Aspergillus aculeatus</i> , XynB xylanase of <i>Ruminococcus flavefaciens</i> , domain of CelX cellulase of <i>Clostridium thermocellum</i> and various serine lipases	Dalrymple <i>et al.</i> (1997), Upton & Buckley (1995)
<i>faeA</i>	CEH	<i>Aspergillus niger</i> / <i>Aspergillus tubingensis</i>	GH <u>S</u> LG	Active site of <i>Rhizopus delemar</i> , <i>Rhizomucor miehei</i> , <i>Humicola lanuginosa</i> and <i>Penicillium camembertii</i>	de Vries <i>et al.</i> (1997)
<i>rba1</i>	RGAE	<i>Aspergillus aculeatus</i>	Not identified	PAE of <i>Erwinia chrysanthemi</i>	Kauppinen <i>et al.</i> (1995)
<i>axe1</i>	AXE	<i>Thermoanaerobacterium</i> spp.	GP <u>S</u> QG	Cephalosporin-C deacetylase of <i>Bacillus subtilis</i>	Lorenz & Wiegel (1997)
<i>ace1</i>	AXE	<i>Aspergillus awamori</i>	G <u>S</u> SSG	AXE of <i>Aspergillus niger</i> , lipases of <i>Geotrichum candidum</i> and <i>Candida cylindracea</i>	Koseki <i>et al.</i> (1997)

* Active site residues are shown underlined in bold.

Mechanism of induction

Location of genes within a single bacterial operon is strong evidence that the encoded proteins share a particular function (e.g. hemicellulose degradation, pectin degradation), and ensures that all the genes required to effect that function are translated. Genes encoding cell-wall-degrading esterases located in an operon with other genes encoding proteins which effect a similar function have been demonstrated in *E. chrysanthemi* (Shevchik & Hugouvieux-Cotte-Pattat, 1997). The operon contains the *paeY* (pectin acetyl-esterase), *pelD* (pectinase) and *pemA* (pectin methyl-esterase) genes as a contiguous strand running from a promoter proximal to *pelD*. Some genes are also found in clusters. Examples of gene clusters which include cell-wall-degrading esterases are found in *Ps. fluorescens* subsp. *cellulosa*, where a xylanase (XynB) and an arabinofuranosidase (XynC) were transcribed from the same strand (Ferreira *et al.*, 1993), *Caldocellum saccharolyticum*, where xylanase, xylosidase and acetylxylan esterase genes are linked (Lüthi *et al.*, 1990) and *Str. lividans*, where the *axeA* gene is located

downstream from a xylanase gene (Shareck *et al.*, 1995). However, location of a gene in a cluster need not indicate common functionalities, since although close physically, they may be regulated independently and may be subject to translational control or post-translational modification. Almost all the esterases acting on plant cell walls are induced upon growth on lignocellulosic material (Christov & Prior, 1993) and are subject to glucose-mediated repression. Mono-saccharides are either poor inducers or do not induce esterase production. Multiple forms of esterases are produced, but there is often little evidence to show if these forms are different gene products or post-translationally altered products of a single gene. In *Streptomyces*, some esterases were constitutively expressed, but production increased (up to 100-fold) upon growth on an inducing substrate (Johnson *et al.*, 1988).

Induction of plant-cell-wall-degrading esterases has rarely been examined at the level of transcription, most of the results being measurements of increased (or decreased) enzyme production in culture filtrates, and

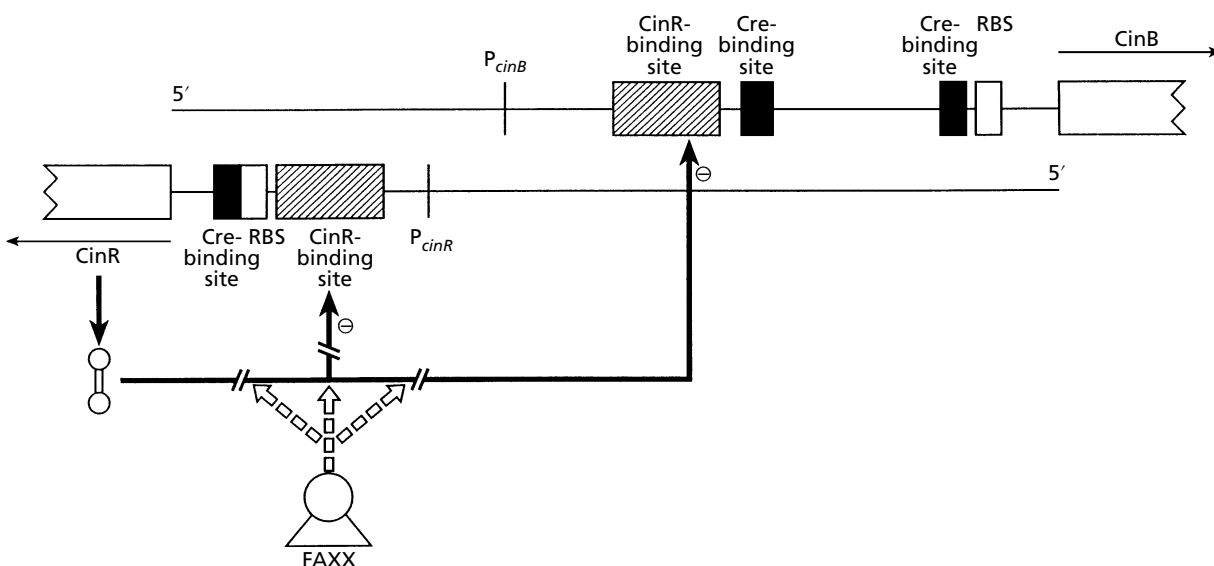

Fig. 3. Proposed regulatory mechanism of a cinnamoyl esterase from *B. fibrisolvens* (based on Dalrymple & Swadling, 1997). The regulation of a cinnamoyl esterase (CinB) may be controlled by both glucose catabolite repression (putative Cre-binding sites) and a negative repressor (CinR), encoded immediately upstream of *cinB* on the opposite strand. CinR is a helix–turn–helix DNA-binding protein (AATTAGATATCTAATT). Promoter regions and putative CinR-, ribosomal- (RBS) and Cre-binding sites are located in the *cinB*–*cinR* intragenic region. Feruloylated oligosaccharides, such as *O*-[5-*O*-(*trans*-feruloyl)- α -L-arabinofuranosyl]-(1 \rightarrow 3)-*O*- β -D-xylopyranosyl-(1 \rightarrow 4)-D-xylopyranose (FAXX), restrict CinR repression by an undetermined mechanism, but monomeric ferulic acid and sugars do not. CinR is also autoregulated.

often the effects on growth rate are not fully described. With the results to date, it is difficult to predict if apparent ‘inducers’ are true inducers, precursors of the actual inducers, or acting as repressors of another (unknown) component. For cinnamoyl esterases and acetylxylan esterases of *Sch. commune*, highest enzyme production was detected during growth on Avicel (a cellulose derivative), compared to wheat bran and xylan (the poorest inducer) (MacKenzie & Bilous, 1988). A similar pattern of induction on these growth substrates was found for an acetyl (xylan) esterase from *A. niger* (Linden *et al.*, 1994). However, high activity of both acetylxylan esterase and cinnamoyl esterase is found during growth of micro-organisms on lignocellulose-derived compounds. The production of acetylxylan esterase from *Pen. purpurogenum* is dependent on the degree of acetylation of the carbon source used, the best being chemically acetylated xylan (35% acetylation; Egana *et al.*, 1996).

The nature of the plant cell wall as growth substrate controls the production of esterase, but there are apparent exceptions. There was no correlation between the amount of esterified ferulic acid and production of *Aspergillus oryzae* cinnamoyl esterase (Tenkanen *et al.*, 1991). In contrast, cinnamoyl esterase production was increased by growth on non-feruloylated carbon source cultures with added free ferulic acid (Borneman *et al.*, 1990b; Faulds *et al.*, 1997).

The regulation of cinnamoyl esterases has been examined in more detail in *B. fibrisolvens*. A putative

negative regulator of the gene (*cinB*) encoding cinnamoyl ester hydrolase (cinnamoyl esterase) is encoded by another gene (*cinR*) immediately upstream of *cinB* (Dalrymple & Swadling, 1997). This regulator protein is similar to HpcR (4-hydroxyphenylacetic acid regulator), a negative regulator of the homoprotocatechuate degradative operon of *Escherichia coli* C (Roper *et al.*, 1993), and PecS, a negative regulator of pectinase, cellulase and blue pigment production in *E. chrysanthemi* (Reverchon *et al.*, 1994). CinR bound to a region between *cinR* and *cinB*, and did not affect the production of another cinnamoyl esterase (CinA; Dalrymple *et al.*, 1996). However, in the presence of feruloylated oligosaccharides, binding of CinR to the intragene region was almost completely abolished. This did not occur in the presence of monomeric cinnamic acids, cellobiose, xylobiose or chlorogenic acid (caffeoyl-quinic acid). There is a requirement for both the sugar and the hydroxycinnamic acid moieties of an esterified compound for induction of this enzyme from *B. fibrisolvens*. Fig. 3 summarizes this regulatory mechanism for CinB. Other microbes may have different regulatory mechanisms; for example, free ferulic acid induces *A. niger* and *Neocallimastix* cinnamoyl esterases (Faulds *et al.*, 1997; Borneman *et al.*, 1990b). The pectin acetylerase (PaeY) from *E. chrysanthemi* is located on an operon with a pectin methylesterase and three pectate lyases. *paeY* gene transcription is subject to indirect regulation through a KdgR repressor, which controls all steps of pectin catabolism in this organism, and an activator (CRP; catabolite regulatory protein). These

transcription regulators bind to the operon promoter region. However, a rho-independent terminator is located in the intergenic region between *pelD* and *paeY* (Shevchik & Hugouvieux-Cotte-Pattat, 1997). *paeY* induction in the presence of polygalacturonate is dependent on the KdgR/2-keto-3-deoxygluconate couple. 2-Keto-3-deoxygluconate, a pectin catabolite product, causes dissociation of the repressor from its binding site.

Pectin methylesterases from *A. niger* are induced by pectin and pectic acid at the transcriptional level, and repressed by glucose, possibly at the translational level (Maldonado *et al.*, 1989). Constitutive enzyme production occurs in cultures grown on monomeric sugars (only those which are constituents of pectin), but increases 14-fold with polymeric pectin, galacturonic acid or polygalacturonic acid as the carbon source. This suggests that induction of the esterases is linked to the production of other pectinolytic cell-wall-acting enzymes. Acetylxylan esterases are apparently an integral component of the enzyme systems of *T. reesei* and *Sch. commune* that degrade cellulose and hemicellulose, and may be, at least partially, under a common regulatory control with cellulases and xylanases in these fungi (Tenkanen, 1995). Comparable expression patterns for the mRNA encoding rhamnogalacturonan esterase and two rhamnogalacturonases produced by *A. aculeatus* grown on soybean/glucose implies that they are co-ordinately regulated at the level of transcription, and also subjected to carbon catabolite repression (Kauppinen *et al.*, 1995). In both *A. niger* (Faulds *et al.*, 1997) and *Streptomyces avermitilis* (Garcia *et al.*, 1998), feruloyl esterase and xylanase induction appear to be under different regulatory mechanisms. In the case of *A. niger*, free ferulic acid inhibited the production of xylanase while inducing the feruloyl esterases.

Future problems and issues to be addressed

Microbial esterases acting on plant cell wall polymers represent key tools for degradation of plant cell wall polysaccharides, modification of physical and chemical properties of plant cell walls and components, and elucidation of plant cell wall structure. The field is at an early stage, and there is a lot of work that needs to be done on the enzymology, especially three-dimensional structures and site-directed mutagenesis combined with rigorous kinetics to enhance understanding of binding sites, substrate recognition and catalytic mechanism. Cloning of more enzymes would allow classes and relationships between these esterases to be identified. Further work on the structure of the plant cell wall is required, helped by the existence of highly purified esterases, to improve understanding of the synergistic interactions between enzymes. There are many unanswered questions concerning regulation of expression, including full gene sequences, extent of co-ordinate regulation and molecular mechanisms in response to putative inducers. The esterases discussed here do not degrade the main chain of plant polysaccharides,

but can make the difference between a good and bad enzyme preparation used in the food and other industries. Often an unexpected variable in existing enzyme preparations could be due to variations in accessory enzyme content, which is not quality controlled. Future advances in applications will include construction of recombinant strains with enzyme profiles tailored for specific applications.

Acknowledgements

We thank the Biotechnology and Biological Sciences Research Council, UK, for funding, Dr David Archer for critical reading of the manuscript, and Dr Brian Dalrymple for discussions on induction.

References

- Akin, D. E., Sethuram, A., Morrison, W. H., Martin, S. A. & Eriksson, K. E. L. (1993). Microbial delignification with white-rot fungi improves forage digestibility. *Appl Environ Microbiol* **59**, 4274–4283.
- Bachman, S. L. & McCarthy, A. J. (1991). Purification and cooperative activity of enzymes constituting the xylan-degrading system of *Thermomonospora fusca*. *Appl Environ Microbiol* **57**, 2121–2130.
- Bajpai, P. (1997). Enzymic deinking. *Adv Appl Microbiol* **45**, 241–269.
- Bartolomé, B., Faulds, C. B., Tuohy, M., Hazlewood, G. P., Gilbert, H. J. & Williamson, G. (1995). Influence of different xylanases on the activity of ferulic acid esterase on wheat bran. *Biotechnol Appl Biochem* **22**, 65–73.
- Bartolomé, B., Faulds, C. B., Kroon, P. A., Waldron, K., Gilbert, H. J., Hazlewood, G. & Williamson, G. (1997). An *Aspergillus niger* esterase (FAE-III) and a recombinant *Pseudomonas fluorescens* subsp. *cellulosa* esterase (XYLD) release a 5-5' ferulic dehydro-dimer ('diferulic acid') from barley and wheat cell-walls. *Appl Environ Microbiol* **63**, 208–212.
- Biely, P., MacKenzie, C. R., Puls, J. & Schneider, H. (1986). Co-operativity of esterases and xylanases in enzymatic degradation of acetylxylan. *Bio/Technology* **4**, 731–733.
- Biely, P., Cote, G. L., Kremnický, L., Greene, R. V., Dupont, C. & Kluepfel, D. (1996). Substrate specificity and mode of action of acetylxylan esterase from *Streptomyces lividans*. *FEBS Lett* **396**, 257–260.
- Biely, P., Cote, G. L., Kremnický, L., Greene, R. V. & Tenkanen, M. (1997). Action of acetylxylan esterase from *Trichoderma reesei* on acetylated methyl glucosides. *FEBS Lett* **420**, 121–124.
- Borneman, W. S., Akin, D. E. & VanEseltine, W. P. (1986). Effect of phenolic monomers on ruminal bacteria. *Appl Environ Microbiol* **52**, 1331–1339.
- Borneman, W. S., Hartley, R. D., Himmelsbach, D. S. & Ljungdahl, L. G. (1990a). Assay for *trans-p*-coumaroyl esterase using a specific substrate from plant cell walls. *Anal Biochem* **190**, 129–133.
- Borneman, W. S., Hartley, R. D., Morrison, W. H., Akin, D. E. & Ljungdahl, L. G. (1990b). Feruloyl and *p*-coumaroyl esterase from anaerobic fungi in relation to plant cell wall degradation. *Appl Environ Microbiol* **33**, 345–351.
- Borneman, W. S., Ljungdahl, L. G., Hartley, R. D. & Akin, D. E. (1992). Purification and partial characterisation of two feruloyl esterases from the anaerobic fungus *Neocallimastix* strain MC-2. *Appl Environ Microbiol* **58**, 3762–3766.

- Brett, C. & Waldron, K. W. (1990).** *Physiology and Biochemistry of Plant Cell Walls*. London: Unwin Hyman.
- Castaneres, A., McCrae, S. I. & Wood, T. M. (1992).** Purification and properties of a feruloyl/*p*-coumaroyl esterase from the fungus *Penicillium pinophilum*. *Enzyme Microb Technol* **14**, 875–884.
- Christgau, S., Kofod, L. V., Halkier, T., Andersen, L. N., Hockauf, M., Dörreich, K., Dalbøge, H. & Kauppinen, S. (1996).** Pectin methyl esterase from *Aspergillus aculeatus*: expression cloning in yeast and characterisation of the recombinant enzyme. *Biochem J* **319**, 705–712.
- Christov, L. P. & Prior, B. A. (1993).** Esterases of xylan-degrading micro-organisms: production, properties, and significance. *Enzyme Microb Technol* **15**, 460–475.
- Coughlan, M. P. & Hazlewood, G. P. (1993).** β -1,4-D-Xylan-degrading systems: biochemistry, molecular biology and applications. *Biotechnol Appl Biochem* **17**, 259–289.
- Dalrymple, B. P. & Swadling, Y. (1997).** Expression of a *Butyrivibrio fibrisolvens* E14 gene (*cinB*) encoding an enzyme with cinnamoyl esterase activity is negatively regulated by the product of an adjacent gene (*cinR*). *Microbiology* **143**, 1203–1210.
- Dalrymple, B. P., Swadling, Y., Cybinski, D. H. & Xue, G.-P. (1996).** Cloning of a gene encoding cinnamoyl ester hydrolase from the ruminal bacterium *Butyrivibrio fibrisolvens* E14 by a novel method. *FEMS Microbiol Lett* **143**, 115–120.
- Dalrymple, B. P., Cybinski, D. H., Layton, I., McSweeney, C. S., Xue, G.-P., Swadling, Y. J. & Lowry, J. B. (1997).** Three *Neocallimastix patriciarum* esterases associated with the degradation of complex polysaccharides are members of a new family of hydrolases. *Microbiology* **143**, 2605–2614.
- Davidson, P. M. & Branen, A. L. (1981).** Anti-microbial activity of non-halogenated phenolic compounds. *J Food Prot* **44**, 597–603.
- Donaghy, J. & McKay, A. M. (1997).** Purification and characterisation of a feruloyl esterase from the fungus *Penicillium expansum*. *J Appl Microbiol* **83**, 718–726.
- Duwe, B. & Khanh, N. Q. (1996).** Site-directed mutagenesis of the active site of pectin methyl esterase from *Aspergillus niger* RH5344. *Biotechnol Lett* **18**, 621–626.
- Egana, L., Gutierrez, R., Caputo, V., Peirano, A., Steiner, J. & Eyzaguirre, J. (1996).** Purification and characterisation of two acetylxylan esterases from *Penicillium purpogenum*. *Biotechnol Appl Biochem* **24**, 33–39.
- Faulds, C. B. & Williamson, G. (1994).** Purification and characterization of a ferulic acid esterase (FAE-III) from *Aspergillus niger*: specificity for the phenolic moiety and binding to microcrystalline cellulose. *Microbiology* **140**, 779–787.
- Faulds, C. B. & Williamson, G. (1995).** Release of ferulic acid from wheat bran by an *Aspergillus niger* ferulic acid esterase. *Appl Microbiol Biotechnol* **43**, 1082–1087.
- Faulds, C. B., de Vries, R. P., Kroon, P. A., Visser, J. & Williamson, G. (1997).** Influence of ferulic acid on the production of feruloyl esterases by *Aspergillus niger*. *FEMS Microbiol Lett* **157**, 239–244.
- Ferreira, L. M. A., Wood, T. M., Williamson, G., Faulds, C. B., Hazlewood, G. P. & Gilbert, H. J. (1993).** A modular esterase from *Pseudomonas fluorescens* subsp. *cellulosa* contains a non-catalytic binding domain. *Biochem J* **294**, 349–355.
- García, B. L., Ball, A. S., Rodriguez, J., Perez-Leblic, M. I., Arias, M. E. & Copa-Patino, J. L. (1998).** Induction of ferulic acid esterase and xylanase activities in *Streptomyces avermitilis* UAH30. *FEMS Microbiol Lett* **158**, 95–99.
- de Graaff, L. H., Visser, J., van den Broeck, H. C., Strozyk, F., Kormelink, F. J. M. & Boonman, J. C. (1992).** Cloning, expression and use of acetylxylan esterase from fungal origin. European Patent 0507369A3.
- Hoseney, R. C. & Faubion, J. M. (1981).** A mechanism for the oxidative gelation of wheat flour water-soluble pentosans. *Cereal Chem* **58**, 421–423.
- Hwang, J. & Kokini, J. L. (1992).** Contribution of the side branches to rheological properties of pectins. *Carbohydr Polym* **19**, 41–50.
- Iiyama, K., Lam, T. B. T. & Stone, B. A. (1994).** Covalent cross-links in the cell wall. *Plant Physiol* **104**, 315–320.
- Ikegawa, T., Mayama, S., Nakayashiki, H. & Kato, H. (1996).** Accumulation of diferulic acid during the hypersensitive response of oat leaves to *Puccinia coronata* f sp *avenae* and its role in the resistance of oat tissues to cell wall degrading enzymes. *Physiol Mol Plant Pathol* **48**, 245–255.
- Ishii, S., Kiho, K., Sugiyama, S. & Sugimoto, H. (1979).** Low-methoxyl pectin prepared by pectinesterase from *Aspergillus niger*. *J Food Sci* **44**, 611–614.
- Johnson, K. G., Harrison, B. A., Schneider, H., MacKenzie, C. R. & Fontana, J. D. (1988).** Xylan-hydrolysing enzymes from *Streptomyces* spp. *Enzyme Microb Technol* **10**, 403–409.
- Kamisaka, S., Takeda, S., Takahashi, K. & Shibata, K. (1990).** Diferulic and ferulic acid in the cell wall of *Avena* coleoptiles – their relationships to mechanical properties of the cell wall. *Physiol Plant* **78**, 1–7.
- Kauffman, S., Doares, S. H., Albersheim, P. & Darvill, A. (1990).** Involvement of pathogen-secreted enzymes and plant cell wall derived xylan fragments in plant cells in the rice blast system. In *5th International Symposium on the Molecular Genetics of Plant-Microbe Interactions*, abstract SO106, p. 32. Interlaken.
- Kauppinen, S., Christgau, S., Kofod, L. V., Halkier, T., Dörreich, K. & Dalbøge, H. (1995).** Molecular cloning and characterization of a rhamnogalacturonan acetyl esterase from *Aspergillus aculeatus*. *J Biol Chem* **270**, 27172–27178.
- Kohn, R., Markovic, O. & Machova, E. (1983).** De-esterification mode of pectin by pectin esterases of *Aspergillus foetidus*, tomatoes and alfalfa. *Collect Czech Chem Commun* **48**, 790–797.
- Kormelink, F. J. M., Lefebvre, B., Strozyk, F. & Voragen, A. G. J. (1993).** Purification and characterisation of an acetylxylan esterase from *Aspergillus niger*. *J Biotechnol* **27**, 267–282.
- Koseki, T., Furuse, S., Iwano, K., Sakai, H. & Matsuzawa, H. (1997).** An *Aspergillus awamori* acetyl esterase: purification of the enzyme and cloning and sequencing of the gene. *Biochem J* **326**, 485–490.
- Kroon, P. A. & Williamson, G. (1996).** Release of ferulic acid from sugar beet pulp using arabinanase, arabinofuranosidase and an esterase from *Aspergillus niger*. *Biotechnol Appl Biochem* **23**, 263–267.
- Kroon, P. A., Faulds, C. B. & Williamson, G. (1996).** Purification and characterisation of a novel esterase induced by growth of *Aspergillus niger* on sugar-beet pulp. *Biotechnol Appl Biochem* **23**, 255–262.
- Kroon, P. A., Faulds, C. B., Brezillon, C. & Williamson, G. (1997).** Methyl phenylalkanoates as substrates to probe the active site of esterases. *Eur J Biochem* **248**, 245–251.
- Laurie, J. I., Clarke, J. H., Ciruela, A., Faulds, C. B., Williamson, G., Gilbert, H. J., Rixon, J. E., Millward-Sadler, J. & Hazlewood, G. P. (1997).** The NodB domain of a multidomain xylanase from *Cellulomonas fimi* deacetylates acetylxylan. *FEMS Microbiol Lett* **148**, 261–264.
- Lesage-Meessen, L., Delattre, M., Haon, M., Thibault, J.-F., Colonna Ceccaldi, B., Brunerie, P. & Asther, M. (1996).** A two-step bioconversion process for vanillin production from ferulic acid

- combining *Aspergillus niger* and *Pycnoporus cinnabarinus*. *J Biotechnol* **50**, 107–113.
- Linden, J., Samara, M., Decker, S., Johnson, E., Boyer, M., Pecs, M., Adney, W. & Himmel, M. (1994). Purification and characterisation of an acetyl esterase from *Aspergillus niger*. *Appl Biochem Biotechnol* **45/46**, 383–393.
- Lorenz, W. W. & Wiegel, J. (1997). Isolation, analysis, and expression of two genes from *Thermoanaerobacterium* sp. strain JW/SL YS485: a β -xylosidase and a novel acetylxyylan esterase with cephalosporin C deacetylase activity. *J Bacteriol* **179**, 5436–5441.
- Lüthi, E., Love, D. R., McNulty, J., Wallace, C., Caughey, P. A., Saul, D. & Bergquist, P. L. (1990). Cloning, sequence analysis, and expression of genes encoding xylan-degrading enzymes from the thermophile '*Caldocellum saccharolyticum*'. *Appl Environ Microbiol* **56**, 1017–1024.
- MacKenzie, C. R. & Bilous, D. (1988). Ferulic acid esterase activity from *Schizophyllum commune*. *Appl Environ Microbiol* **54**, 1170–1173.
- Maldonado, M. C., Srasser de Saad, A. M. & Callieri, D. A. S. (1989). Regulatory aspects of the synthesis of polygalacturonase and pectinesterase by *Aspergillus niger* sp. *Sci Aliment* **9**, 101–110.
- Marchessault, R. H., Settineri, W. & Winter, W. (1967). Crystallisation of xylan in the presence of cellulose. *Tech Assoc Pulp Pap Ind* **50**, 55–59.
- Margolles-Clark, E., Tenkanen, M., Soderlund, H. & Penttila, M. (1996). Acetylxyylan esterase from *Trichoderma reesei* contains an active site serine residue and a cellulose-binding domain. *Eur J Biochem* **237**, 553–560.
- Markovic, O., Stovickova, J. & Jornvall, H. (1996). Modification of tomato and *Aspergillus niger* pectinesterases with diethyl pyrocarbonate. *J Protein Chem* **15**, 127–131.
- Mitchell, D. J., Grohmann, K. & Himmel, M. E. (1990). Effect of the degree of acetylation on the enzymatic digestion of acetylated xylan. *J Wood Chem Technol* **10**, 111–121.
- Moore, J., Bamforth, C. W., Kroon, P. A., Bartolomé, B. & Williamson, G. (1996). Ferulic acid esterase catalyses the solubilisation of β -glucans and pentosans from the starchy endosperm cell walls of barley. *Biotechnol Lett* **18**, 1423–1426.
- Pangborn, W., Erman, M., Li, N. & 8 other authors (1996). Characterisation of crystals of *Penicillium purpurogenum* acetylxyylan esterase from high resolution X-ray diffraction. *Proteins Struct Funct Genet* **24**, 523–524.
- Pitson, S. M., Voragen, A. G. J., Vincken, J. P. & Beldman, G. (1997). Action patterns and mapping of the substrate-binding regions of *endo*-(1 \rightarrow 5)- α -L-arabinanases from *Aspergillus niger* and *Aspergillus aculeatus*. *Carbohydr Res* **303**, 207–218.
- Poutanen, K., Sundberg, M., Korte, H. & Puls, J. (1990). Deacetylation of xylans by acetyl esterases of *Trichoderma reesei*. *Appl Microbiol Biotechnol* **33**, 506–510.
- Puls, J., Tenkanen, M., Korte, H. E. & Potanen, K. (1991). Products of hydrolysis of beechwood acetyl-4-O-methylglucuronoxylan by a xylanase and an acetylxyylan esterase. *Enzyme Microb Technol* **13**, 483–486.
- Rahouti, M., Seigle-Murandi, F., Steiman, R. & Erikson, K. E. (1989). Metabolism of ferulic acid by *Paecilomyces varioti* and *Pestalotia palmarum*. *Appl Environ Microbiol* **55**, 2391–2398.
- Ralet, M.-C., Faulds, C. B., Williamson, G. & Thibault, J.-F. (1994). Feruloylated oligosaccharides from sugar-beet cell wall polysaccharides. Part III. Degradation by ferulic acid esterases from *Aspergillus niger*. *Carbohydr Res* **263**, 257–269.
- Ralph, J., Quideau, S., Grabber, J. H. & Hatfield, R. D. (1994). Identification and synthesis of new ferulic acid dehydrodimers present in grass cell walls. *J Chem Soc Perkin Trans I* 3485–3498.
- Rao, S. S., Lippincott, B. B. & Lippincott, J. A. (1982). *Agrobacterium tumefaciens* adherence involves the pectic portion of the host cell wall and is sensitive to the degree of pectin methylation. *Physiol Plant* **56**, 374–380.
- Reverchon, S., Nasser, W. & Robert-Baudouy, J. (1994). *pecS*: a locus controlling pectinase, cellulase and blue pigment production in *Erwinia chrysanthemi*. *Mol Microbiol* **11**, 1127–1139.
- Rombouts, F. M. & Pilnik, W. (1986). Pectinases and other cell-wall degrading enzymes of industrial importance. *Symbiosis* **2**, 79–90.
- Roper, D. I., Fawcett, T. & Cooper, R. A. (1993). The *Escherichia coli* C homoprotocatechuate degradative operon: *hpc* gene order, direction of transcription and control of expression. *Mol Gen Genet* **237**, 241–250.
- Ross, N. W., Johnson, K. G., Braun, C., MacKenzie, C. R. & Schneider, H. (1992). Enzymic hydrolysis of water-soluble lignin-carbohydrate complexes from *Populus deltoides*: effects of combinations of β -mannanases, xylanase, and acetylxyylan esterase. *Enzyme Microb Technol* **14**, 90–95.
- Searle-van Leeuwen, M. J. F., van den Broek, L. A. M., Schols, H. A., Beldman, G. & Voragen, A. G. J. (1992). Rhamnogalacturonan acetyl esterase: a novel enzyme from *Aspergillus aculeatus*, specific for the deacetylation of hairy (ramified) regions of pectins. *Appl Microbiol Biotechnol* **38**, 347–349.
- Shareck, F., Biely, P., Morosoli, R. & Kluepfel, D. (1995). Analysis of DNA flanking the *xinb* locus of *Streptomyces lividans* reveals genes encoding acetylxyylan esterase and the RNA component of ribonuclease P. *Gene* **153**, 105–109.
- Shevchik, V. E. & Hugouvieux-Cotte-Pattat, N. (1997). Identification of a bacterial pectin acetyl esterase in *Erwinia chrysanthemi* 3937. *Mol Microbiol* **24**, 1285–1301.
- Tenkanen, M. (1995). *Characterisation of esterases acting on hemicelluloses*. PhD thesis, Valtion Teknillinen Tutkimuskeskus (VTT), Finland (publication 242).
- Tenkanen, M., Schuseil, J., Puls, J. & Poutanen, K. (1991). Production, purification and characterisation of an esterase liberating phenolic acids from lignocellulose. *J Biotechnol* **18**, 69–84.
- Tolan, J. S. (1996). Pulp and paper. In *Industrial Enzymology*, pp. 327–338. Edited by T. Godfrey & S. West. London: MacMillan.
- Tsujibo, H., Ohtsuki, T., Iio, T., Yamazaki, I., Miyamoto, K., Sugiyama, M. & Inamori, Y. (1997). Cloning and sequence analysis of genes encoding xylanases and acetylxyylan esterase from *Streptomyces thermoviolaceus* OPC-520. *Appl Environ Microbiol* **63**, 661–664.
- Upton, C. & Buckley, J. T. (1995). A new family of lipolytic enzymes? *Trends Biochem Sci* **20**, 178–179.
- de Vries, R. P., Michelsen, B., Poulsen, C. H., Kroon, P. A., van den Heuvel, R. H. H., Faulds, C. B., Williamson, G., Van den Hombergh, J. P. T. W. & Visser, J. (1997). The *faeA* genes from *Aspergillus niger* and *Aspergillus tubingensis* encode ferulic acid esterases involved in degradation of complex cell wall polysaccharides. *Appl Environ Microbiol* **63**, 4638–4644.
- Wakabayashi, K., Hoson, T. & Kamisaka, S. (1997). Osmotic stress suppresses cell wall stiffening and the increase in cell wall-bound ferulic and diferulic acids in wheat coleoptiles. *Plant Physiol* **113**, 967–973.
- Waldron, K. W., Parr, A. J., Ng, A. & Ralph, J. (1996). Cell wall esterified phenolic dimers: identification and quantification by

reverse phase high performance liquid chromatography and diode array detection. *Phytochem Anal* **7**, 305–312.

Whitaker, J. R. (1984). Pectic substances, pectic enzymes and haze formation in fruit juices. *Enzyme Microb Technol* **6**, 341–349.

Williamson, G., Faulds, C. B., Matthew, J. A., Archer, D. B., Morris, V. J., Brownsey, G. J. & Ridout, M. J. (1990). Gelation of sugarbeet

and citrus pectins using enzymes extracted from orange peel. *Carbohydr Polym* **13**, 387–397.

York, W. S., Oates, J. E., van Halbeek, H., Darvill, A. G., Albersheim, P., Tiller, P. R. & Dell, A. (1988). Location of the O-acetyl substituents on a nonasaccharide repeating unit of sycamore extracellular xyloglucan. *Carbohydr Res* **173**, 113–132.