

SGM SPECIAL LECTURE

1999 Fleming Lecture

(Delivered at the 144th meeting of the Society for General Microbiology, 8 September 1999)

Bacterial respiration: a flexible process for a changing environment

David J. Richardson

Tel: +44 1603 593250. Fax: +44 1603 592250. e-mail: d.richardson@uea.ac.uk

School of Biological Sciences, University of East Anglia, Norwich, NR4 7TJ, UK

Keywords: bacterial respiration, nitrate reductase, nitric oxide reductase, Fe(III) respiration, nitrogen cycle

Overview

The respiration of oxygen is fundamental to the life of higher animals and plants. The basic respiratory process in the mitochondria of these organisms involves the donation of electrons by low-redox-potential electron donors such as NADH. This is followed by electron transfer through a range of redox cofactors, bound to integral membrane or membrane-associated protein complexes. The process terminates in the reduction of the high-redox-potential electron acceptor, oxygen (Fig. 1). The free energy released during this electron-transfer process is used to drive the translocation of protons across the mitochondrial membrane to generate a *trans*-membrane proton electrochemical gradient or protonmotive force (Δp) that can drive the synthesis of ATP (Fig. 1). The respiratory flexibility of the mammalian mitochondrion is rather poor. There is some flexibility at the level of electron input (Fig. 1), but none at the level of electron output where cytochrome *aa*₃ oxidase provides the only means of oxygen reduction. In the case of plant mitochondria, a slightly greater degree of respiratory flexibility is encountered with a number of alternative NADH dehydrogenases and two oxidases being apparent. This respiratory flexibility affords plant mitochondria with the capacity to contribute to processes other than the generation of ATP. For example, electron transfer from the alternative NADH dehydrogenase to the alternative oxidase is not coupled to the generation of Δp and instead serves to release energy as heat, which can volatilize insect attractants to aid pollination. In the American skunk cabbage this same mechanism for heat production serves to permit growth at subzero temperatures (Nicholls & Ferguson, 1992). There is also some respiratory flexibility in the mitochondria of yeast, filamentous fungi and ancient protozoa, but it is amongst the Bacteria and Archaea that respiratory flexibility can be found at its most extreme. In these organisms, a diverse range of electron acceptors can be utilized including elemental sulphur and sulphur oxyanions (Hamilton, 1998), organic sulphoxides and

sulphonates (Lie *et al.*, 1999; McAlpine *et al.*, 1998), nitrogen oxy-anions and nitrogen oxides (Berks *et al.*, 1995), organic N-oxides (Czjzek *et al.*, 1998), halogenated organics (Dolfing, 1990; Louie & Mohn, 1999; van de Pas *et al.*, 1999), metalloid oxy-anions such as selenate and arsenate (Krafft & Macy, 1998; Macy *et al.*, 1996, 1993; Schroder *et al.*, 1997), transition metals such as Fe(III) and Mn(IV) (Lovley, 1991), and radionuclides such as U(VI) (Lovley & Phillips, 1992) and Tc(VII) (Lloyd *et al.*, 1999). This respiratory diversity can be found amongst psychrophiles, mesophiles and hyperthermophiles and contributes to the ability of prokaryotes to colonize many of Earth's most hostile micro-oxic and anoxic environments.

A good example of respiratory flexibility can be found in *Paracoccus denitrificans*, a soil bacterium that is a member of the α -proteobacteria and thought to be a close relative of the original progenitor of the mitochondrion (Fig. 2). This bacterium is equipped with genes that encode three biochemically distinct oxidases (de Gier *et al.*, 1994). One of these, the cytochrome *aa*₃ oxidase, operates at high oxygen tensions and terminates a highly coupled electron-transfer pathway. However, at lower oxygen tensions the high-affinity cytochrome *cbb*₃ oxidase becomes more important and a cytochrome *c* peroxidase is also expressed to enable the energy-conserving detoxification of the partially reduced toxic oxygen species hydrogen peroxide (H₂O₂). Under anaerobic conditions, enzymes that are capable of reducing nitrogen oxy-anions and nitrogen oxides are expressed (Berks *et al.*, 1995a). These can be coupled to the core electron-transport pathway at the level of the ubiquinol pool or the cytochrome *bc*₁ complex, and enable growth and metabolism of the organism in anoxic environments. Thus, by modulating expression of different terminal oxido-reductases, which 'lock' onto a core electron-transfer system, it is possible for *Paracoccus denitrificans* to survive and proliferate in a range of oxic, micro-oxic and anoxic environments and adapt quickly in a rapidly changing environment.

A combination of biochemistry and genome sequence

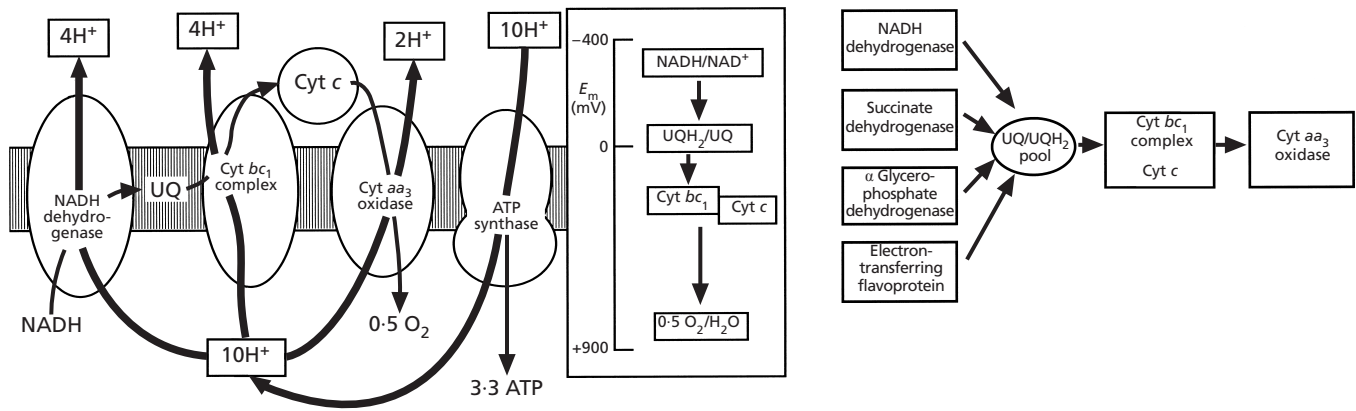

Fig. 1. A summary of the topology and bioenergetics of a basic aerobic respiratory electron transport system of a mammalian mitochondrion. UQ, ubiquinone; UQH₂, ubiquinol; Cyt, cytochrome.

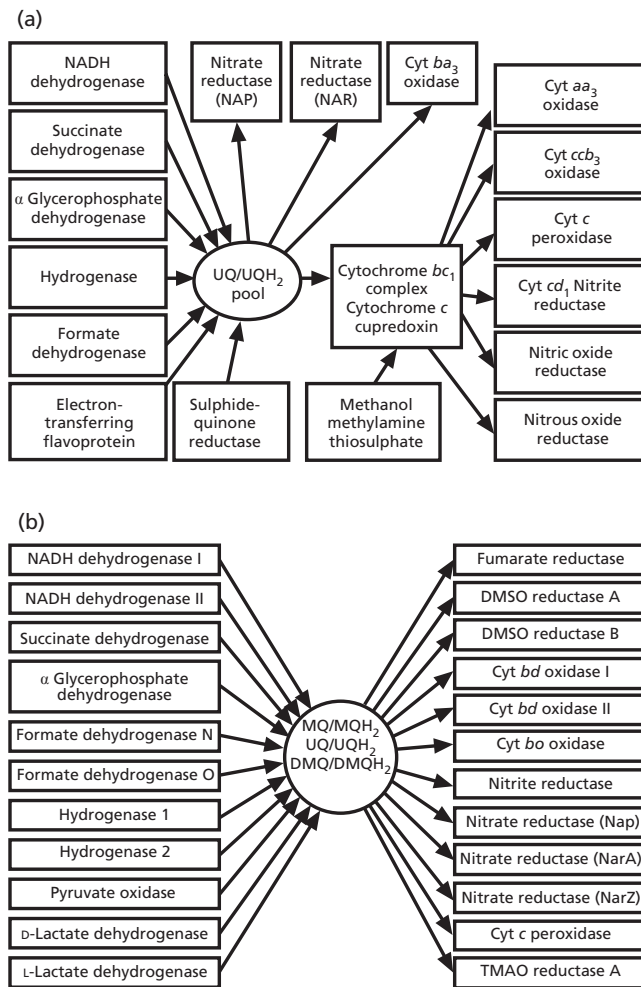

Fig. 2. Respiratory flexibility in *Paracoccus denitrificans* (a) and *Escherichia coli* (b). MQ, menaquinone; UQ, ubiquinone; DMQ, demethylmenaquinone.

analysis is revealing respiratory flexibility in many Bacterial and Archaeal branches. Amongst enteric bacteria, biochemical and genome analysis of *Escherichia coli* reveals considerable flexibility in both electron input and output. In this case there is no cytochrome *bc*₁ complex, but a number of electron acceptors can be utilized, including oxygen, nitrate, nitrite, dimethylsulphoxide (DMSO), trimethylamine *N*-oxide (TMAO) and fumarate (Blattner *et al.*, 1997). Furthermore, analysis of the genome reveals multiple biochemically distinct enzymes that catalyse the same reaction, for example the cytochrome *bd* oxidase and the cytochrome *bo* oxidase, the former of which has a high affinity for oxygen and is expressed under micro-oxic conditions (D'mello *et al.*, 1996). Respiratory flexibility is also apparent in the emerging genomes of many pathogenic bacteria, including *Helicobacter pylori*, *Mycobacterium tuberculosis* and *Haemophilus influenzae* (Cole *et al.*, 1998; Fleischmann *et al.*, 1995; Tomb *et al.*, 1997). Studying the nature, degree and regulation of this respiratory flexibility in pathogens will make a significant contribution to understanding the survival of these bacteria both inside and outside the host organism. Recent examples of developments in this area include the suggestion that cytochrome *bd* oxidase is important in *Shigella flexneri* virulence (Way *et al.*, 1999), that the NarZ membrane-bound nitrate reductase of *Salmonella typhimurium* is stress-induced and expressed at high levels in cultured kidney epithelial cells (Spector *et al.*, 1999), and that the copper-type nitrite reductase of *Neisseria gonorrhoeae* is detected in sera of patients suffering from gonococcal infections (Householder *et al.*, 1999; Hoehn & Clark, 1992; Berks *et al.*, 1995a).

Amongst the Archaea, methanogens can utilize CO₂, acetate or methanol as electron acceptors, with H₂ as the electron donor, in the strictly anaerobic process of methanogenesis, which can be considered as a respiratory process as it is coupled to the generation of a H⁺ or Na⁺ electrochemical gradient. The complexity of

methanogenesis is clearly apparent from analysis of the genomes of the strictly anaerobic hyperthermophile *Methanococcus jannaschii* (Bult *et al.*, 1996) and moderate thermophile *Methanobacterium thermoautotrophicum* (Smith *et al.*, 1997) and was reviewed recently by Thauer (1998). The genome of the anaerobic hyperthermophilic sulphate respirer *Archeoglobus fulgidus* has also been sequenced and reveals a genetic potential for respiratory flexibility not yet recognized by biochemical studies and which might include the ability to utilize Fe(III), nitrate, DMSO, polysulphide, fumarate, heterodisulphides and oxygen as electron acceptors (Klenk *et al.*, 1997). Another sulphate-reducing hyperthermophile, *Pyrobacterium aerophilum*, has been demonstrated to utilize nitrate or oxygen (at low partial pressures) as growth-supporting respiratory substrates (Volkl *et al.*, 1993). Amongst the aerobic Archaea (e.g. *Sulfolobus acidocaldarius*), the study of oxygen respiration has been the focus of some attention, leading to the identification of haem-copper oxidases (HCOs) that are related to the HCOs of Bacteria. Indeed, analysis of protein sequences in current databases of Bacteria and Archaea reveal that a number of respiratory proteins are homologous in both domains of life. In addition to HCOs these include nitrate reductase, DMSO reductase, adenylylsulphate reductase, sulphite reductase and polysulphide reductase, and cytochrome *bd* oxidase. Thus, it seems likely that these respiratory pathways arose early in evolution and that the last common ancestor of living organisms was not a simple organism in its energetic metabolism and that its respiratory flexibility enabled it to proliferate under a range of environmental conditions (Castresana & Moreira, 1999).

One of the respiratory processes that probably evolved before the last common ancestor was denitrification, in which nitrate is reduced via nitrite, nitric oxide and nitrous oxide to dinitrogen (Berks *et al.*, 1995). One of the enzymes involved in this process, nitrate reductase, binds a complex organic cofactor [the bis-molybdopterin guanine dinucleotide (*bis*-MGD) cofactor], which lies at the heart of a number of different respiratory enzymes (Kisker *et al.*, 1997). Another two, nitric oxide reductase and nitrous oxide reductase, have together evolved into the cytochrome *aa₃* oxidase that catalyses much of the oxygen respiration on earth today (Saraste, 1994; Saraste & Castresana, 1994; van der Oost *et al.*, 1994; Watmough *et al.*, 1999). The absence of photosynthetic reaction centres in Archaea, and the presence of oxidases of similar primary structure in both Bacteria and Archaea, has led to the 'respiration-first' hypothesis. It is argued that oxygen levels began to increase on early Earth before the onset of oxygenic photosynthesis (Castresana & Saraste, 1995; Schafer *et al.*, 1996). Thus the original oxidases were high-affinity enzymes that evolved from the nitric oxide reductase. Some of these may still exist today in the guise of the high-affinity bacterial cytochrome *cbb₃* oxidases (Preisig *et al.*, 1993; Saraste & Castresana, 1994). The original role of these early HCOs and the unrelated high-affinity cytochrome *bd* oxidase may have been to protect

oxygen-labile enzymes from destruction by oxygen. Such roles can be seen, for example in the respiratory protection of nitrogenase by cytochrome *bd* in *Azotobacter vinelandii* (Poole & Hill, 1997) and by cytochrome *cbb₃* in *Bradyrhizobium japonicum* (Preisig *et al.*, 1993). The lower-affinity cytochrome *aa₃* oxidases may then have evolved subsequently in response to increasing oxygen levels in many environments.

A review detailing progress of study on all of the prokaryotic respiratory systems is beyond the scope of any article and in this paper only some of the key respiratory reactions currently under study in the author's laboratory will be addressed, namely Fe(III) respiration, nitrate respiration and nitric oxide reductase. In doing so, attention will be paid to the flexible use of particular proteins or cofactors in a range of other respiratory reactions and also to flexible use of the respiratory process itself in functions other than the generation of Δp .

Bacterial Fe(III) respiration

Fe(III) reduction: an ancient respiratory process

It is generally agreed that the first respiratory processes to evolve in the hyperthermal reducing environment of early Earth, over 3.5 billion years ago, would have utilized either Fe(III) or S(0) as electron acceptors. It has recently been argued that Fe(III) respiration preceded sulphur respiration (Vargas *et al.*, 1998) since Fe(III), derived from photochemical oxidation of Fe(II) from Archean seas and hydrothermal-vent fluids, was abundant on early earth and Fe(III) respiration has been demonstrated in a number of deep-branching hyperthermophilic Archaea and Eubacteria, many of which do not respire S(0) (Vargas *et al.*, 1998). Intriguingly, it has been pointed out that extracellular magnetite accumulations characteristic of Fe(III) respiring prokaryotes are associated with some of the putative fossilized microbes found in ancient Martian meteorites (McKay *et al.*, 1996; Vargas *et al.*, 1998).

An early importance for Fe(III) respiration in microbial life is also attractive because it would not have required the evolution of complex cofactors and redox proteins. The respiratory reduction of Fe(III) and other transition metals is largely dependent on a sufficient thermodynamic driving force and an appropriate long-range electron-transfer system. This need not require specific enzymes, indeed it is unlikely that there are specific iron reductases operating in any of the hyperthermophiles recently reported as Fe(III)-respiring bacteria (Vargas *et al.*, 1998). A simple early respiratory process for Fe(III) is likely to have utilized hydrogen as an electron donor with electrons being extracted via an extra-membranous hydrogenase. The scalar protons produced from hydrogen oxidation would contribute to the generation of a proton gradient across the membrane. In this context, it is also notable that the hydrogenase (Hyc) of the formate hydrogen lyase system of *Escherichia coli* has been reported to provide the organism with the capacity for technetium reduction (Lloyd *et al.*, 1997). Hydrogen-

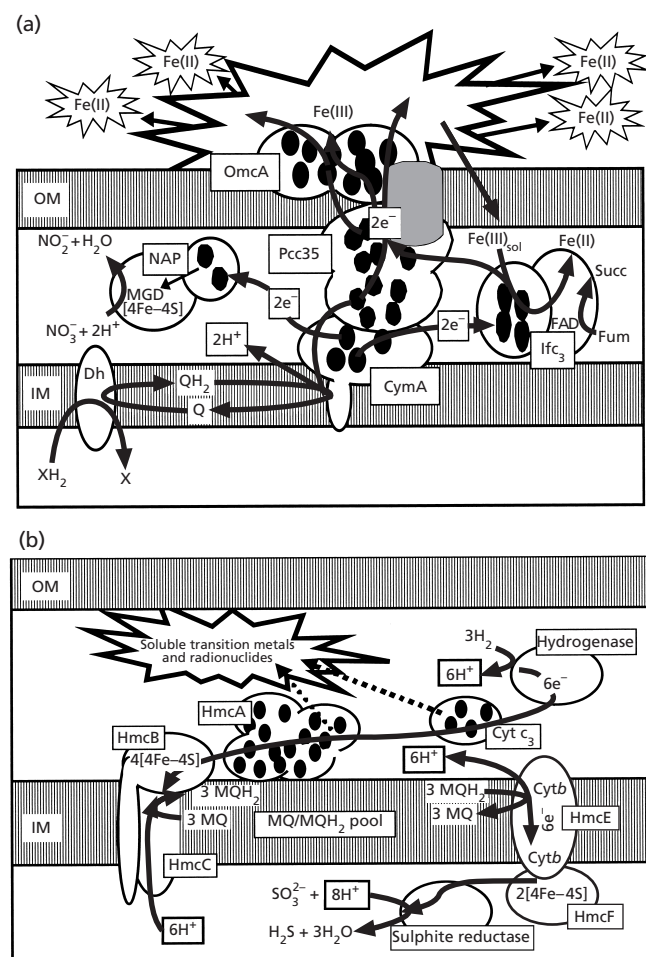

Fig. 3. Metal ion reduction by Gram-negative bacteria. (a) A hypothetical scheme showing the involvement of inner-membrane, periplasmic and outer-membrane multi-haem cytochromes in Fe(III) respiration by *Shewanella frigidimarina*. (b) A hypothetical electron-transfer system for soluble metal ion reduction and sulphite reduction in sulphate-reducing bacteria involving multi-haem cytochromes of the cytochrome c_3 family. HmcA, B, C, E and F are the products of *orfs* 1, 2, 3, 5 and 6 of the *hmc* operon. The model is based on the data of Rossi *et al.* (1993) and the arguments of Berks *et al.* (1995). Haem groups are represented by black ovals. OM, outer membrane; IM, inner membrane.

driven Fe(III) respiration in hyperthermophiles may account for observations of magnetite accumulation at depths of 6.7 km in the Earth's core (Gold, 1992; Lovley, 1997).

Fe(III) respiration in mesophilic Gram-negative bacteria

Although Fe(III) respiration may have originally evolved in hydrothermal environments on early Earth and can be identified in a number of hyperthermophilic Archaea, the process is also known to be widespread amongst a number of branches of the Bacteria (Lonergan *et al.*, 1996) and contributes significantly to the biogeochemical development of a number of mesophilic anoxic

environments (Lovley, 1991). Indeed, the activity of Fe(III)-respiring bacteria can have an impact on the populations of both sulphate- and nitrate-reducing bacteria in these environments, and hence impact on the nitrogen and sulphur cycles in general (Lovley, 1991). The activity of Fe(III)-respiring bacteria can be detrimental, for example in the corrosion of deep-sea oil pipes, but it can also potentially be harnessed for the bioremediation of polluted anoxic subsurface zones (Lovley *et al.*, 1994). The major problem of utilizing Fe(III) as a respiratory substrate is the insolubility of the cation at circum-neutral pH. The soluble $Fe^{III}(H_2O)_6$ species only exists at $pH < 2$ and the use of Fe(III) as an electron acceptor by sulphur-oxidizing acidophiles (e.g. *Thiobacillus ferrooxidans*) has been reported (Sugio *et al.*, 1992). However, as the pH increases, deprotonation and dehydration events lead to the formation of complex oxo/hydroxo bridged precipitates (e.g. rust). An Fe(III)-respiring Gram-negative bacterium then faces the problem of moving electrons generated from carbon metabolism in the cytoplasm across two cell membranes and the intervening periplasm to the site of reduction of the insoluble extracellular species.

In the case of the members of the Fe(III)-respiring genus *Shewanella*, it is emerging that this problem may be solved by using a number of tetra-haem and deca-haem *c*-type cytochromes to form a multi-haem electron 'wire' between the inner and the outer membranes (Beliaev & Saffarini, 1998; Field *et al.*, 2000; Myers & Myers, 1997a,b, 1998) (Fig. 3a). Accordingly, when cells of *Shewanella frigidimarina* are grown under anaerobic conditions with Fe(III) present as the electron acceptor, the expression of cytochromes greatly increases compared to cells grown anaerobically with fumarate present as the electron acceptor (Dobbin *et al.*, 1999), and addition of Fe(III) complexes to anaerobically incubated cells results in the 'drain' of electrons from the total cytochrome pool (Dobbin *et al.*, 1995, 1996a). Some of the multi-haem cytochromes purified from *Shewanella frigidimarina* grown with Fe(III) include a 20 kDa tetra-haem membrane-anchored quinol dehydrogenase (CymA), a 35 kDa periplasmic deca-haem cytochrome (Pcc35), a 60 kDa iron-induced flavocytochrome c_3 (Ifc₃) and an outer-membrane 80 kDa deca-haem lipoprotein (OmcA) (Dobbin *et al.*, 1999; Field *et al.*, 2000; P. S. Dobbin, S. J. Field, M. Ellington & D. J. Richardson, unpublished) (Fig. 3a). It is becoming apparent that the genes for many of these cytochromes are present in multiple copies on the *Shewanella putrefaciens* genome, for example one recently characterized gene cluster (GenBank accession no. AF083240) contains three outer-membrane deca-haem lipoproteins and two periplasmic deca-haem proteins (Beliaev & Saffarini, 1998). This increased gene dosage presumably enables the bacteria to drive the high levels of cytochrome expression required to facilitate rapid reduction of the surrounding insoluble Fe(III) species.

The means by which electrons proceed from redox centres in the periplasm to redox centres on the outer face of the outer membrane has not yet been established.

Direct electron transfer may be possible. However, genes predicted to encode outer-membrane β -barrel proteins cluster with some of the multi-haem cytochromes, and the possibility that these bind a redox centre has been raised (Beliaev & Saffarini, 1998; Dobbin *et al.*, 1999).

In the model for Fe(III) respiration shown in Fig. 3a, the reduction of Fe(III) is probably via non-specific long-range electron transfer. The multi-haem cytochromes themselves are not specific Fe(III) reductases. Indeed the soluble periplasmic multi-haem cytochromes have Fe(III) reductase activity but are not physiological reductases for the insoluble species because of their cellular location (Dobbin *et al.*, 1999). However, adding Fe(III) chelators such as nitriloacetic acid can accelerate the rate of Fe(III) reduction, which may be because the soluble species can enter the periplasm where they can be reduced by the large pool of low-potential periplasmic cytochromes (Dobbin *et al.*, 1995, 1996a, b, 1999). Furthermore, the non-specific nature of the multi-haem Fe(III) reductase system makes it suitable for reduction of a range of extracellular substrates, such as Mn(IV) and insoluble sulphur species (Beliaev & Saffarini, 1998; Lovley, 1991).

Diverse respiratory functions of periplasmic multi-haem c-type cytochromes

Consideration of the multi-haem cytochromes involved in Fe(III) respiration in conjunction with recent structural studies on multi-haem cytochromes is beginning to give insight into the evolution of these proteins. Sequence analysis of the deca-haem cytochromes involved in Fe(III) respiration suggests that they are composed of two penta-haem units which show some similarity to the 16 kDa penta-haem NrfB protein of some enteric bacteria (Beliaev & Saffarini, 1998; Hussein *et al.*, 1994). NrfB is involved in electron transfer to the 50 kDa NrfA protein which is a nitrite reductase and which also has a penta-haem core (Darwin *et al.*, 1993; Einsle *et al.*, 1999) (Fig. 4). Recent structural analysis increases the members of this multi-haem protein family further to include some tetra-haem and octa-haem proteins. Fig. 4 shows the haem arrangement of four such proteins. One of these is the Fe(III)-induced periplasmic flavocytochrome c_3 , which is an isozyme of a soluble fumarate reductase (Fcc₃) also expressed by the *Shewanella* species and for which structures are also known (Bamford *et al.*, 1999; Taylor *et al.*, 1999; Leys *et al.*, 1999). The tetra-haem arrangement of the haems in this protein includes an intriguing haem-haem pair in which the haem-irons are only 9 Å apart and the closest haem edges are only 4 Å apart. Inspection of the octa-haem arrangement in the hydroxylamine oxidoreductase (HAO) (Igarashi *et al.*, 1997) reveals that the four Ifc₃/Fcc₃ haems can be superimposed onto four of the HAO haems. The four Ifc₃ haems also have a similar arrangement to four of the haems from the penta-haem NrfA-type nitrite reductase (Einsle *et al.*, 1999) and all five haems from this enzyme overlay on five of the HAO haems. Finally two of the haems from the Ifc₃ overlay onto two of the

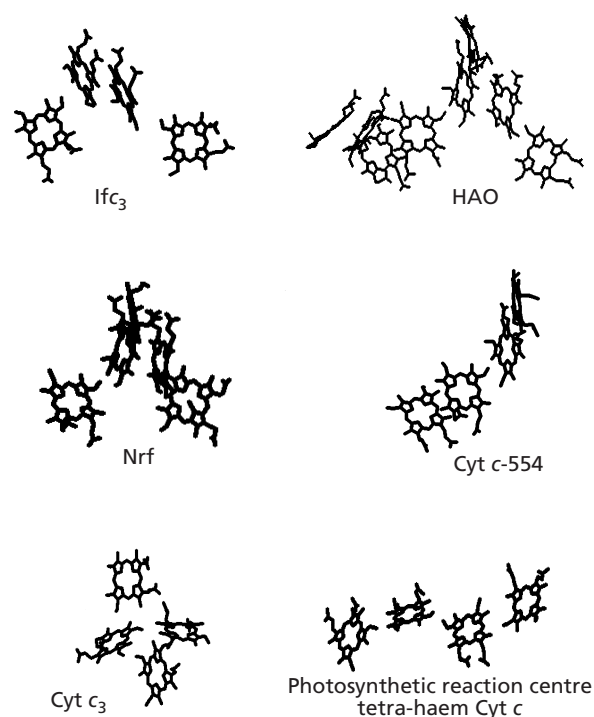

Fig. 4. A comparison of the organization of the haem groups in the multi-haem cytochromes of the HAO/Nrf family, cytochrome c_3 and the photosynthetic reaction centre tetra-haem cytochrome *c*. The sources of the proteins are: Ifc₃, *Shewanella frigidimarina*; HAO, *Nitrosomonas europaea*; Nrf, *Sulfurospirillum deleyianum*; Cyt *c*-554, *Nitrosomonas europaea*; Cyt c_3 , *Desulfovibrio gigas* (Simoes *et al.*, 1998); and photosynthetic reaction centre tetra-haem cyt *c*, *Rhodospseudomonas viridis*

four haems of cytochrome *c*-554 (Iverson *et al.*, 1998), from which all four haems will superimpose on the HAO (Fig. 4). Despite this conservation of haem organization, little similarity can be seen between these four proteins at the primary-structure level. Nevertheless, this analysis suggests that all four multi-haem cytochromes share a common evolutionary origin but have diverged for use in four distinct periplasmic electron-transfer processes: Fe(III) reduction, fumarate reduction (Fig. 3a), hydroxylamine oxidation (Fig. 5) and nitrite reduction to ammonia (Fig. 5). The conservation of the haem-haem angles and distances in these periplasmic electron-transfer processes. Given the non-enzymic nature of long-range electron transfer, it seems likely that these multi-haem cytochromes evolved for functions such as protein-protein electron transfer and non-specific reduction of respiratory substrates, and later evolved other catalytic activities through the evolution of the polypeptide chain yielding specialized active sites around a catalytic haem.

Members of the Nrf/HAO multi-haem cytochrome family have quite distinct haem arrangements from the tetra-haem subunit that lies at the periplasmic face of the *Rhodospseudomonas viridis* photosynthetic reaction

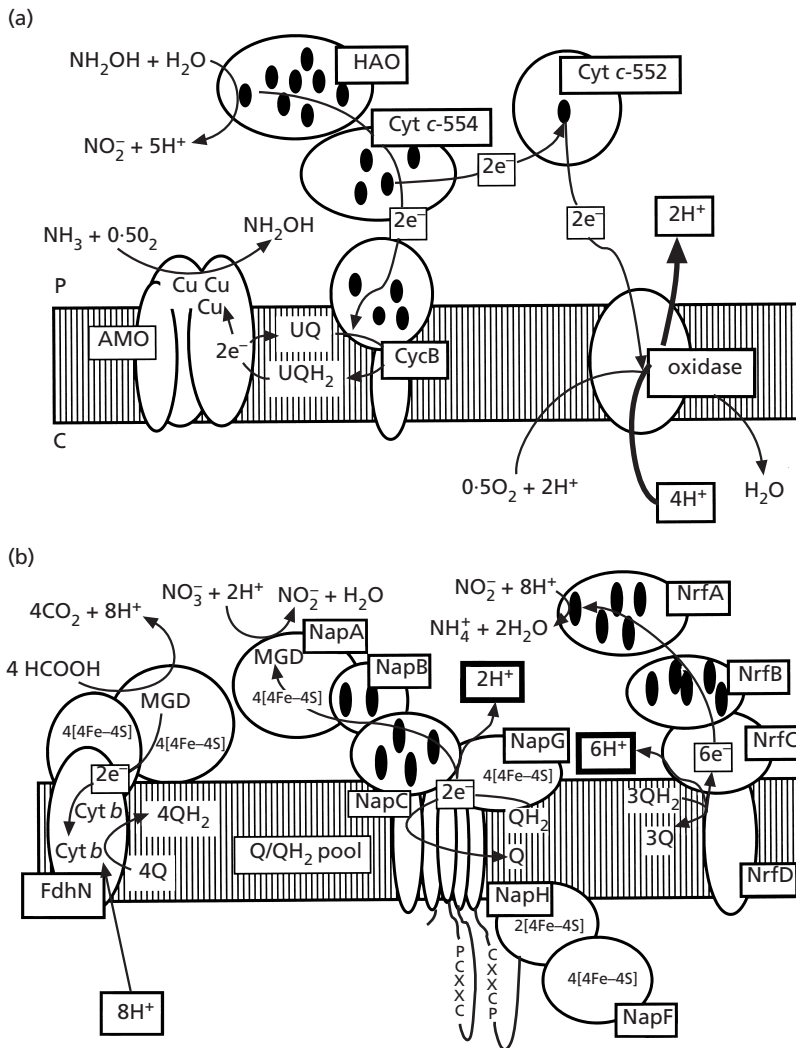

Fig. 5. Model schemes of the electron-transport systems in which the multi-haem cytochromes of the HAO/Nrf family participate. (a) The scheme for HAO represents a possible electron-transport system for ammonia oxidation in *Nitrosomonas europaea*. (b) The scheme for Nrf represents a possible electron-transport system for periplasmic nitrate reduction to ammonium in *Escherichia coli*. Haem groups are represented by black ovals. P, periplasm; C, cytoplasm.

centre and those of the multi-haem cytochrome c_3 family found in many sulphate-reducing bacteria, such as *Desulfovibrio vulgaris*. The latter group of cytochromes are likely to be associated with the electron transfer from periplasmic hydrogenases to the membrane components involved in transfer of electrons across the membrane to facilitate cytoplasmic sulphite reduction (Fig. 3b). These family members can bind up to 16 haems, but the gene duplication of tri- and tetra-haem units (Fig. 5) is usually clearly apparent and consequently nona-haem, octa-haem and dodeca-haem polypeptides of this family have been reported (Matias *et al.*, 1999; Pollock *et al.*, 1991). These cytochrome c_3 proteins may also be involved in the non-specific reduction of transition metals and radionuclides that have been reported in a number of sulphate-reducing bacteria (Lovley *et al.*, 1993). These are particularly adept at reducing soluble metal ions such as U(VI) which can easily access the periplasmic cytochromes, and industrial use of these can be made in the reductive precipitation of such metals, e.g. reduction of U(VI) to insoluble U(IV), which could be harnessed in bioremediation of polluted waters (Lovley & Coates, 1997).

The inter-membrane electron-transfer system that operates during Fe(III) respiration in *Shewanella* species requires a means of extracting electrons from membrane-entrapped quinol and directing them into the periplasmic compartment. This is true for a number of bacterial respiratory systems that involve periplasmic oxido-reductases and one solution to the problem seems to have been the evolution of the NapC family of membrane-anchored tetra/penta-haem cytochromes (Roldan *et al.*, 1998). Members of this family have been implicated in mediating electron transfer from quinols to a range of oxido-reductases that include the nitrate reductase (NapC) (Roldan *et al.*, 1998), the periplasmic DMSO reductase (DorC) (Shaw *et al.*, 1999), the TMAO reductase (TorC) and some cytochrome cd_1 nitrite reductases (NirT) (Jungst *et al.*, 1991). In the case of CycB (Bergmann *et al.*, 1994), they may also serve to transfer electrons into the ubiquinone (UQ) pool during nitrification by *Nitrosomonas europaea* (Fig. 5a). The CymA protein involved in Fe(III) respiration in *Shewanella putrefaciens* is also a member of this family and additionally serves to transfer electrons to the periplasmic fumarate reductase and the periplasmic

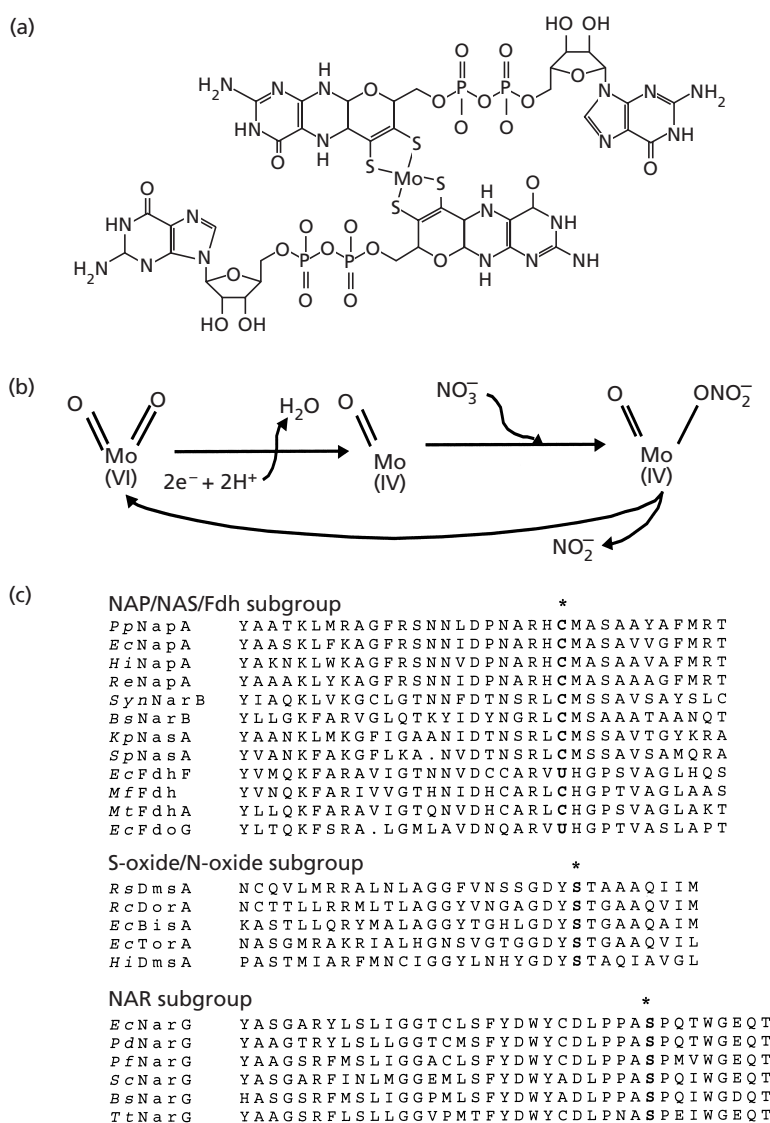

Fig. 7. The catalytic centre of the nitrate reductases. (a) The bis-MGD cofactor. (b) A possible catalytic cycle for NAP of *Paracoccus pantotrophus*. (c) An alignment of the segment 3 region of some members of the bis-MGD family. *PpNapA*, *Paracoccus pantotrophus* NAP; *EcNapA*, *Escherichia coli* NAP; *HiNapA*, *Haemophilus influenzae* NAP; *ReNapA*, *Ralstonia eutropha* NAP; *SynNarB*, *Synechocystis* NAS; *BsNarB*, *Bacillus subtilis* NAS; *KpNasA*, *Klebsiella pneumoniae* NAS; *SpNasA*, *Shewanella putrefaciens* NAS; *EcFdhF*, *Escherichia coli* formate dehydrogenase F, *MfFdh*, *Methanobacterium formicicum* formate dehydrogenase; *MtFdhA*, *Methanobacterium thermoautotrophicum* formate dehydrogenase; *EcFdoG*, *Escherichia coli* formate dehydrogenase O; *RSDmsA*, *Rhodobacter sphaeroides* DMSO reductase; *RcDorA*, *Rhodobacter capsulatus* DMSO reductase; *EcBisA*, *Escherichia coli* biotinsulphoxide reductase; *EcTorA*, *Escherichia coli* TMAO reductase; *HiDmsA*, *Haemophilus influenzae* DMSO reductase; *EcNarG*, *Escherichia coli* membrane-bound nitrate reductase A; *PpNarG*, *Paracoccus pantotrophus* NAR; *PfNarG*, *Pseudomonas fluorescens* NAR; *ScNarG*, *Staphylococcus carnosus* NAR; *BsNarG*, *Bacillus subtilis* NAR A; *TtNarG*, *Thermus thermophilus* NAR. The asterisk indicates proven or speculative Mo-coordinating residues.

to regenerate the oxo group on the Mo(VI) species (Fig. 7b). The thionate reductases most probably catalyse reactions involving either sulphur, rather than oxygen transfer, or reductive cleavage of an S–S bond (Hensel *et al.*, 1999). In the case of formate dehydrogenases, the Mo probably works in conjunction with a nearby amino acid base to catalyse direct proton abstraction from the HCOO^- (Khangulov *et al.*, 1998).

Almost all the characterization of bis-MGD enzymes

has been carried out in Bacteria. However, nitrate-reducing Archaea are known (Volkl *et al.*, 1993) and putative bis-MGD-binding enzymes can be identified from primary-structure analysis of ORFs in the genome sequence of *Archaeoglobus fulgidus* which suggest the presence of nitrate, DMSO and polysulphide reductases. It should be noted that no biochemical data are available on these enzymes and the possibility that they bind tungsten rather than molybdenum at the active site

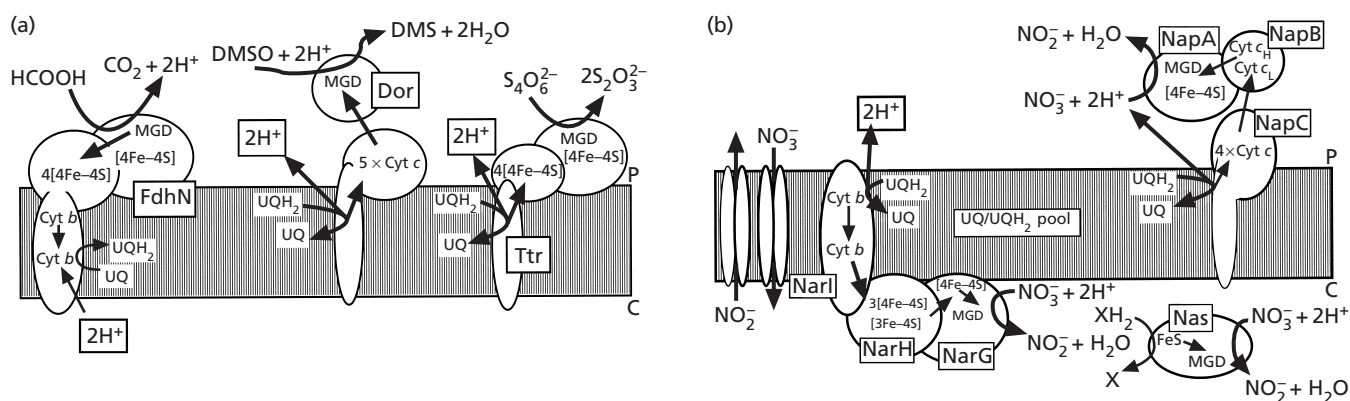

Fig. 8. (a) The topological organization of some bis-MGD enzymes. FdhN, *Escherichia coli* formate dehydrogenase N; Dor, *Rhodobacter capsulatus* periplasmic DMSO reductase; Ttr, *Salmonella typhimurium* tetrathionate reductase. (b) The nitrate reductases of *Paracoccus* species. NarGHI, the membrane-bound nitrate reductase; NapABC, the periplasmic nitrate reductase. P, periplasm; C, cytoplasm.

cannot be excluded. Indeed, the inclusion of tungstate in the growth medium of *Pyrobacterium aerophilum* stimulates anoxic growth with nitrate (Volkl *et al.*, 1993) and active W-substituted TMAO reductase from *Escherichia coli* has been reported (Buc *et al.*, 1999). However, the presence of putative bis-M(W)GD enzymes in Archaea suggests an early evolution for these respiratory reactions, before the last universal ancestor.

The structures of some of the catalytic subunits of members of the bis-MGD family have emerged in recent years from the formate dehydrogenase (Boyington *et al.*, 1997), DMSO reductase (McAlpine *et al.*, 1998; Schindelin *et al.*, 1996), TMAO reductase (Czjzek *et al.*, 1999) and a periplasmic nitrate reductase from the sulphate-reducing bacterium *Desulfovibrio desulfuromonas* (Dias *et al.*, 1999). All the subunits show a high degree of similarity in the structural organization with the bis-MGD cofactor lying at the bottom of a deep substrate cleft. However, there is some debate over the number of oxo groups bound to the Mo in these enzymes. Crystal structures and spectroscopic studies indicate one oxo group in the Mo(VI) form of *Rhodobacter sphaeroides* DMSO reductase (Schindelin *et al.*, 1996) and two in the Mo(VI) form of *Rhodobacter capsulatus* DMSO reductase (McAlpine *et al.*, 1998). Similarly with nitrate reductases, EXAFS (Extended X-ray Absorption Fine Structure) studies on *Paracoccus denitrificans* periplasmic nitrate reductase indicate a di-oxo Mo(VI) state (Fig. 7b) (Butler *et al.*, 1999) and crystal-structure studies on *Desulfovibrio desulfuricans* periplasmic nitrate reductase suggest a mono-oxo Mo(VI) state (Dias *et al.*, 1999). Studies with model oxo-molybdenum complexes have demonstrated that some can exhibit a broad specificity of oxo-transferase chemistry. Thus, for example, some can exhibit both nitrate reductase and DMSO reductase activity (Craig & Holm, 1989). This contrasts to the bis-MGD enzymes where a nitrate reductase does not exhibit DMSO reductase activity and a DMSO reductase does not exhibit nitrate reductase activity. Clearly the evolution of the poly-

peptide around the bis-MGD cofactor has played a major role in conferring catalytic selectivity and this is reflected in differences in the amino acids that line the substrate cleft and that lie in the catalytic pocket. In the case of DMSO reductase, mutation of the Mo-coordinating serine residues has altered catalytic specificity (Hilton *et al.*, 1999).

The multiple nitrate reductases of *Paracoccus* species

Perhaps not surprisingly, given the multiple roles for nitrate in bacteria, it has emerged that many bacteria can express multiple biochemically distinct nitrate reductases. For example, *Paracoccus denitrificans* and *Paracoccus pantotrophus* have three nitrate reductases (Sears *et al.*, 1997). One of these, NAS (cytoplasmic assimilatory nitrate reductase), is located in the cytoplasmic compartment, is ammonium repressible and participates in nitrogen assimilation. The other two, however, are both linked to respiratory electron-transport systems, each ultimately taking electrons from the quinol pool (Fig. 8b). One of the enzymes (NAR, membrane-bound nitrate reductase) is a three-subunit complex anchored to the cytoplasmic face of the membrane with its active site located in the cytoplasmic compartment. The other (NAP, periplasmic nitrate reductase) is a two-subunit enzyme located in the periplasmic compartment that is coupled to quinol oxidation via a membrane-anchored tetra-haem cytochrome of the NapC quinol dehydrogenase family, discussed earlier in the context of Fe(III) respiration (Berks *et al.*, 1995a, c; Roldan *et al.*, 1998; Richardson & Watmough, 1999).

Comparison of the primary structure of the catalytic (MGD) subunits of NAR, NAP and NAS suggests that NAP and NAS are most closely related to each other and to the bis-MGD subunits of formate dehydrogenases (Berks *et al.*, 1995a, b). This similarity is particularly well defined in the so-called segment 3 region of the polypeptide chain which provides a Cys or SeCys ligand

to the Mo (Bennett *et al.*, 1996; Berks *et al.*, 1995a, c). The *bis*-MGD subunit of NAR is much larger than that of NAP and NAS (120–140 kDa compared to 80–90 kDa) and there is no conserved cysteine in the segment 3 region of the NARs (Fig. 7c). Rather, there are a number of conserved serine residues, which raises the possibility that NAR has a Mo–O–serine ligand rather than the Mo–S–Cys ligand demonstrated for NAP (Dias *et al.*, 1999) and predicted for NAS (Berks *et al.*, 1995a, c). In this respect, NAR appears more similar to the DMSO reductase subgroup of *bis*-MGD enzymes than to the NAP/NAR/Fdh subgroup. This is also reflected in Mo(V) EPR spectra which show that the Mo(V) environment of NAP and NAS is similar, but likely to be quite distinct from NAR with the latter exhibiting signals that share more similarity with those seen in the *Rhodobacter capsulatus* DMSO reductase (Bennett *et al.*, 1994a, b; Butler *et al.*, 1999). These spectroscopic and primary-structure analyses raise the possibility that nitrate reduction has evolved more than once in the *bis*-MGD family.

Different physiological roles for the membrane-bound and periplasmic nitrate reductases in *Paracoccus* species

An early question that emerged, on discovering two respiratory nitrate reductases in a single organism, was what are their physiological roles? Studies on enzyme expression revealed that NAR was predominantly expressed under anaerobic denitrifying growth conditions, whilst NAP was predominantly expressed under aerobic growth conditions (Bell *et al.*, 1990). Consideration of the bioenergetic properties of each system offers a physiological rationale for this. In the case of NAR, quinol is oxidized at the periplasmic face of the cytoplasmic membrane by the NarI subunit (Fig. 8b). Protons are ejected into the periplasm whilst the electrons flow back across the membrane via the two stacked NarI haems (Rothery *et al.*, 1999). They then pass, via multiple NarH iron–sulphur centres (Magalon *et al.*, 1998), to the cytoplasmic NarG *bis*-MGD cofactor where nitrate is reduced to nitrite with the associated consumption of two protons (Fig. 7b). This electron-transfer process represents a classic Mitchellian electrogenic redox loop and ensures that the free energy in the $\text{QH}_2/\text{NO}_3^-$ redox couple is conserved as Δp (Berks *et al.*, 1995b). The role of an integral di-*b*-haem cytochrome in these sort of redox loops is widespread in bacterial electron-transfer systems (Berks *et al.*, 1995b) (see, for example, the formate dehydrogenase depicted in Fig. 5b) and these simple loops may have evolved before the more complex proton-motive Q cycle of the di-haem cytochrome bc_1 complex (Nicholls & Ferguson, 1992).

In NAP, quinol is also oxidized at the periplasmic face of the cytoplasmic membrane by NapC, but the electrons also flow into the periplasm where they ultimately reduce nitrate to nitrite. Thus, by contrast to the membrane-bound nitrate reductase, the free energy in the $\text{QH}_2/\text{NO}_3^-$ redox couple is not conserved as Δp and

is therefore dissipated (Fig. 8b). In physiological terms, it makes bioenergetic sense to express the energy-coupled NAR system under anaerobic conditions when the organism is dependent on nitrate reduction for energy conservation. The expression of an energy-dissipating system under aerobic conditions immediately raises the possibility of a role for NAP in redox balancing. During chemoheterotrophic growth on reduced carbon sources, the carbon substrate must be oxidized to the level at which it can be assimilated. If this oxidation results in the release of more reductant than is needed for the generation of the ATP required for the metabolism of the carbon then a means of disposing of the excess reductant must be available. If it is not, the growth rate will be slowed to that allowed by the reoxidation of NADH in cell-maintenance reactions. One means of disposing of the excess reductant is via the respiratory electron-transport pathways. However, efficiently coupled pathways (e.g. the cytochrome bc_1 complex/cytochrome-oxidase-dependent pathways) will not turn over at high rates in the presence of a large steady-state Δp . Consequently, the maximum rate of growth-substrate utilization is only possible if electrons are disposed of by relatively uncoupled pathways, such as that provided by NAP.

The need to dissipate reductant is likely to be most acute during the metabolism of a reduced carbon substrate under conditions that are both oxygen and energy sufficient (Sears *et al.*, 1997). Laboratory cultures of denitrifying bacteria are routinely grown on relatively oxidized carbon substrates such as malate or succinate. However, higher levels of intracellular reductant may be generated through the oxidation of more reduced substrates, such as fatty acids, to carbon intermediates suitable for biosynthesis and assimilation. Accordingly, expression of the periplasmic nitrate reductase is 10–40-fold higher following growth of *Paracoccus* species aerobically with butyrate or caproate compared to malate or succinate (Richardson & Ferguson, 1992; Sears *et al.*, 1993). Furthermore, analysis of steady-state cultures of *Paracoccus denitrificans* in butyrate-limited and malate-limited chemostat cultures revealed that aerobic nitrate respiration was only significant in the butyrate-limited cultures. The malate-limited cultures were carbon limited and energy limited, whilst the butyrate-limited cultures were carbon limited but energy sufficient with the excess reductant dissipated through the NAP system (Sears *et al.*, 1997).

A model for the integrated aerobic respiratory and NAP electron-transport systems of *Paracoccus* species is shown in Fig. 9a. Unregulated electron flux through the NAP system would be detrimental to the cell as it would result in an unnecessary wastage of redox energy. A major factor that is likely to influence the destination of electrons entering the respiratory chain from low-potential electron donors is the redox state of the QH_2/Q pool, since this is a redox component that is common to both the oxygen- and nitrate-respiratory pathways. Cellular overreduction will ultimately result

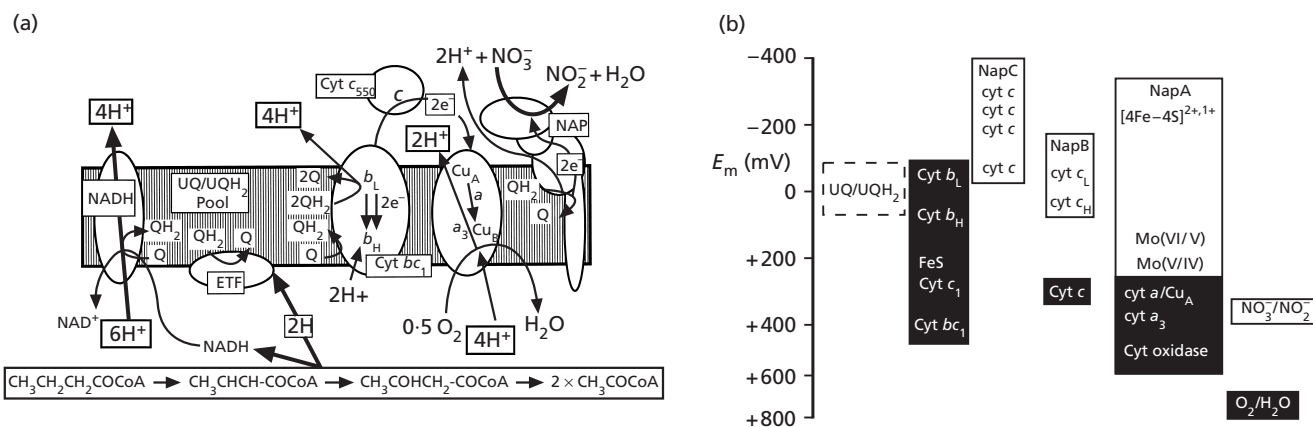

Fig. 9. Aerobic nitrate respiration in *Paracoccus pantrophus*. (a) Scheme for electron transport to oxygen and nitrate during aerobic metabolism of a reduced carbon substrate. The boxed chemical reactions show oxidation of butyryl CoA. ETF, electron-transfer flavoprotein. (b) The midpoint redox potentials of some of the electron-transfer components detailed in (a). White boxes denote the periplasmic nitrate reductase system. Black boxes denote the cytochrome bc₁ complex-dependent oxidase system. For details of the NAP subunits, see Fig. 8b.

in overreduction of the QH₂/Q pool as a consequence of the high NADH/NAD⁺ ratio driving turn over of the Q-dependent NADH dehydrogenase, even in the presence of a high Δp. The resulting increase in the QH₂/Q ratio could ultimately limit turn over of the cytochrome bc₁ complex, since this requires Q as well as QH₂ as substrate (Fig. 9b). The redox components that comprise the NAP electron-transport system have rather low redox potentials and the system depends only on QH₂ (Fig. 9b). Thus electron flow through the NAP system may be slow when the QH₂/Q ratio is low (high E_h) and cytochrome bc₁-dependent electron transport is favoured. At high QH₂/Q ratios, turn over of the cytochrome bc₁ complex becomes limited by Q availability and there is a stronger thermodynamic driving force for electron transport through the NAP system. Reoxidation of QH₂ via NAP will serve to reposit the Q pool, lowering the QH₂/Q ratio so that electron flux switches back to the more highly coupled cytochrome bc₁-dependent oxidase system.

If a means of dissipating excess reducing power is important to the bacterium then it is not a good strategy to rely solely on NAP, as many environments may be nitrate limited. Accordingly, *Paracoccus* strains have many different options for disposing of reductant, which include the coupled processes of ammonia oxidation to nitrite (heterotrophic nitrification) and aerobic nitrite reduction to gaseous N-oxides and N₂ (aerobic denitrification) (Robertson & Kuenen, 1990). Heterotrophic nitrification coupled to aerobic denitrification uses two distinct respiratory processes to remove one QH₂ for every ammonium utilized (Fig. 10b, see below) (Richardson *et al.*, 1998). Other strategies could include the reductive fixation of CO₂, the deposition of polyhydroxyalkanoates or the use of poorly coupled oxidases such as the QH₂-oxidizing cytochrome ba₃ oxidase (Robertson & Kuenen, 1990).

Different physiological roles for the periplasmic nitrate reductase in different bacteria

Since the early identification in the α-proteobacteria of *Paracoccus denitrificans* (Bell *et al.*, 1990), *Ralstonia eutropha* (Siddiqui *et al.*, 1993) and *Rhodobacter* species (Ferguson *et al.*, 1987), genome-sequence analysis, biochemical studies and environmental gene probing (Flanagan *et al.*, 1999) have revealed that NAP is distributed amongst all branches of the proteobacteria, including sulphate-reducing bacteria (Moura *et al.*, 1997) and many pathogens such as *Yersinia pestis*, *Haemophilus influenzae*, *Vibrio cholerae* and *Campylobacter jejuni*. In *Ralstonia eutropha* and other bacteria capable of aerobic nitrate respiration, the role of NAP is likely to be similar to that described above for *Paracoccus* species. However, it is clear when considering the diversity of bacteria that express NAP that it can not have the same physiological function in all bacteria. For example, in *Escherichia coli* NAP is expressed anaerobically rather than aerobically (Darwin & Stewart, 1995; Rabin & Stewart, 1993; Tanapongpipat *et al.*, 1998) and in *Rhodobacter* species it is expressed during anaerobic photoheterotrophic growth (Castillo *et al.*, 1996; Reyes *et al.*, 1998; Richardson *et al.*, 1988).

NAP and photo-nitrate respiration

Members of the *Rhodospirallaceae* family of α-proteobacteria, which includes *Rhodobacter* species, possess a cyclic photosynthetic electron-transport system. This cyclic system relies on a single reaction centre, the cytochrome bc₁ complex, the QH₂/Q pool and one or more c-type cytochromes that mediate electron transfer between the two integral membrane complexes (Fig. 10). Under illuminated conditions the photosynthetic reaction centre will only turn over if there is a supply of oxidized Q as electron acceptor, whilst the protonmotive

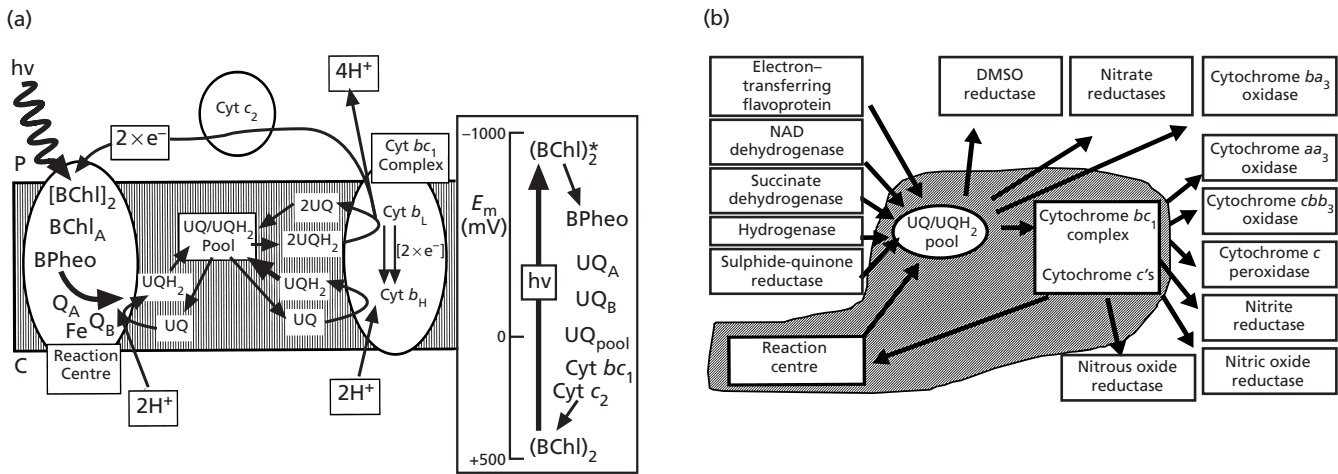

Fig. 10. Generalized electron-transport systems of *Rhodobacter* species. (a) A scheme for cyclic photosynthetic electron transport. (b) Routes for electron input and output into the Q pool. It should be noted that some *Rhodobacter* species and strains within a species are deficient in some of the oxido-reductases indicated. For example, *Rhodobacter capsulatus* does not have a cytochrome aa_3 oxidase, but *Rhodobacter sphaeroides* does, and not all strains of *Rhodobacter capsulatus* have a nitrate reductase. If a strain has a nitrate reductase it is usually periplasmic (NAP) but some have the membrane-bound (NAR) type; some strains of *Rhodobacter sphaeroides* may have both NAP and NAR.

Q cycle of the cytochrome bc_1 complex requires the provision of both Q and QH_2 (Fig. 10a). Consequently, the cyclic electron-transport system is critically dependent on the QH_2/Q ratio in the Q pool. However, the cyclic electron-transport system is not a closed system, there are a number of routes for electron input during photoheterotrophic metabolism (Fig. 10). Thus the UQ/UQH₂ ($E^0 = +80$ mV) pool can be coupled to low-potential electron donors such as NADH (E^0 NADH/NAD⁺ = -330 mV). This could lead to extensive reduction of the UQH₂/UQ pool, restricting the rate of cyclic electron transport. Many strains of *Rhodobacter capsulatus* and *Rhodobacter sphaeroides* have the ability to express a NAP and it has become clear that nitrate reduction can serve to reposition the cyclic electron-transport system when it has become perturbed by overreduction (Ferguson *et al.*, 1987; Jones *et al.*, 1990). This may be particularly important during photoheterotrophic growth of *Rhodobacter capsulatus* on reduced carbon substrates, such as butyrate (Richardson *et al.*, 1988). Many species of the family *Rhodospirillaceae* are only able to photometabolize butyrate anaerobically in the presence of carbon dioxide. Excess reductant generated through the oxidative photometabolism of butyrate can be consumed by the reductive fixation of CO₂, resulting in extensive deposition of poly-3-hydroxybutyrate. However, in the absence of CO₂, photoheterotrophic growth of *Rhodobacter capsulatus* on butyrate can be facilitated through the reduction of nitrate (Richardson *et al.*, 1988). Under energy rich conditions, in the presence of both CO₂ and nitrate, reductive CO₂ fixation is the selected mechanism by which NAD⁺ is regenerated, presumably because it conserves carbon. However, CO₂ fixation also consumes ATP and the choice of mechanism may be different under energy-limited (i.e. light limited) conditions. In

order for nitrate reduction to effectively consume excess reductant, it may be advantageous if the transfer of electrons from ubiquinol to the reductases can continue in the presence of a substantial light-dependent Δp . Since oxidation of ubiquinol by nitrate, via NAP, is not thought to be coupled to the generation of Δp it will not be subject to thermodynamic back-pressure mediated by light-dependent Δp .

During steady-state cyclic electron-transfer on oxidized carbon substrates, thermodynamic back-pressure of the light-dependent Δp on the protonmotive NADH dehydrogenase is a major factor that prevents over-reduction of the cyclic electron-transport chain. Thus at high light intensities nitrate respiration by bacteria utilizing malate (and therefore predominantly NADH) as the electron donor is sensitive to inhibition by the light-dependent Δp (which may be around 200 mV). However, intermittent periods of darkness or prolonged periods of low light intensity could result in the redox poise of the photosynthetic electron-transport system becoming disturbed even during photometabolism of such a relatively oxidized carbon substrate. Under these conditions, the light-dependent protonmotive force could collapse to as low as +50 mV, leading to electron flux into the Q pool from the NADH pool. The effect of prolonged periods of anaerobic dark incubation, in malate medium, on the redox poise of the electron-transfer system of intact cells of *Rhodobacter capsulatus* has been examined and has indicated that the Q/QH₂ pool was extensively reduced, restricting turn over of the reaction centre (Jones *et al.*, 1990). This problem was relieved if nitrate was present during the dark incubation period since NAP, by drawing electrons from the UQ/UQH₂ pool, was serving to maintain the optimal redox poise of the cyclic electron-transfer pathway

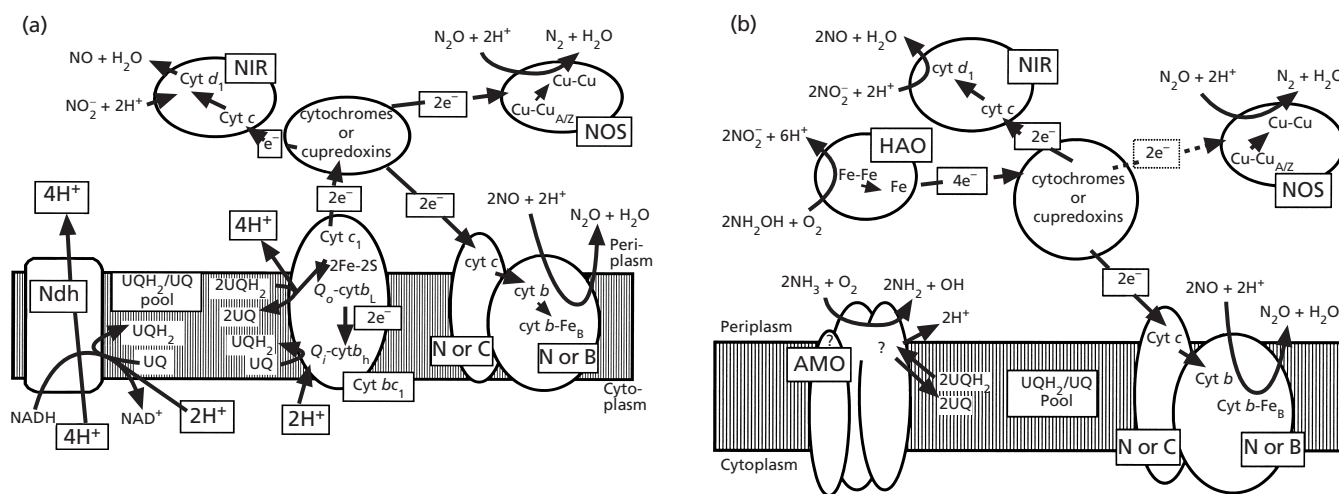

Fig. 11. The role of NOR in the denitrification systems of *Paracoccus* species. (a) Anaerobic denitrification. NIR, cytochrome cd_1 nitrite reductase; NOS, nitrous oxide reductase; NOR, nitric oxide reductase; Ndh, NADH dehydrogenase. (b) The postulated aerobic nitrification–denitrification pathway for dissipation of reductant. AMO, ammonium monooxygenase; HAO, hydroxylamine oxidase. Four electrons generated from hydroxylamine oxidation can be used to reduce the product, nitrite, to nitrous oxide. The nitrous oxide can be released from the cell or be further reduced by electrons generated from subsequent rounds of NH_2OH oxidation.

during the period of darkness (Jones *et al.*, 1990). The light intensity on sediment surfaces is probably rarely as high as routinely used for growth of photosynthetic organisms in laboratory cultures. At low light intensities (and therefore low-light-dependent Δp), the reduction of nitrate, during growth of *Rhodobacter capsulatus* on oxidized carbon substrates such as malate and succinate, is more extensive than at high light intensities. This may be related to the electron-transfer system being more susceptible to overreduction under these conditions (Richardson *et al.*, 1988).

An extreme example of the use of nitrate reduction as a means of regulating the redox poise of the cyclic photosynthetic electron-transport chain of purple non-sulphur photosynthetic bacteria can be found in *Roseobacter denitrificans* which can not grow photosynthetically under anaerobic conditions unless auxiliary oxidants, such as nitrate, are present. The reaction-centre complex of *Roseobacter denitrificans* is very similar to that of the photosynthetically competent *Rhodobacter* species, with the exception that the redox potential of the primary acceptor quinone (Q_A) is higher ($E^0 = +35$ mV compared to -20 mV in *Rhodobacter sphaeroides*). Thus the QH_2/Q pool has to be maintained in a very oxidized state (i.e. at a high redox potential) in order for the reaction centre to turn over and this can be facilitated by the reduction of nitrate (Takamiya, 1988).

Nitrate reductase is not the only accessory oxidant available to photosynthetic bacteria during photoheterotrophic metabolism. The respiratory flexibility of these bacteria is such that DMSO, TMAO, NO_2^- , N_2O , (Ferguson *et al.*, 1987), NO (Bell *et al.*, 1992) and Fe(III) (Dobbin *et al.*, 1996a) can all be used as respiratory substrates and many of these have been demonstrated to

serve redox-poising roles (Jones *et al.*, 1990; McEwan *et al.*, 1985; Richardson *et al.*, 1988; Takamiya *et al.*, 1988). Furthermore, in strains of *Rhodobacter sphaeroides* in which the CO_2 -fixation pathway has been inactivated, spontaneous mutants can arise which have deregulated nitrogenase so that reductive fixation of nitrogen can serve to facilitate cellular redox balance (Qian & Tabita, 1998).

NAP and nitrate scavenging

Escherichia coli can, in principle, express either a NAR or a NAP type of nitrate reductase under anaerobic growth conditions. The q^+/e^- (ratio of the charges translocated across the membrane per electron transferred through the respiratory system) for nitrate reduction by NAR would be 6 or 4 with NADH or formate as electron donor, but only 4 (NADH) and 2 (formate) when NAP is used to reduce nitrate. Given that NAR is more highly coupled than NAP, the question then arises as to when the NAP system is expressed and physiologically important. This has been addressed in recent competition experiments in continuous cultures where a strain expressing only NAR has been placed in competition with a strain expressing only NAP. Under nitrate-limited conditions the strain expressing NAR is out-competed, but the situation is reversed under carbon-limited conditions where the strain expressing NAP is out-competed (Potter *et al.*, 1999). This may reflect a low K_s (higher affinity) for intact cells for nitrate when the NAP system is expressed. Thus NAP may be important in scavenging nitrate from nitrate-limited environments and consequently under these conditions coupling efficiency is sacrificed in favour of substrate affinity. Expression studies of Nap in *Escherichia coli* support this view point since the *nap* operon is induced

at low nitrate concentrations but repressed at higher nitrate concentrations which induce the *narG* operon (Wang *et al.*, 1999). In this context, it becomes significant that many of the pathogenic bacteria that may have to scavenge nitrate from the low levels present in many bodily fluids have the genetic information for NAP. Indeed, in some of these (e.g. *Haemophilus influenzae*) NAP is the only nitrate reductase present. It should be noted that consideration of the *nap* gene clusters of enteric bacteria reveals some heterogeneity in their composition. For example, in addition to the *napAB* genes that encode the NAP enzyme, the *nap* gene cluster of *Escherichia coli* contains additional genes (*napFGH*) that are predicted to encode membrane-associated iron-sulphur clusters (NapFGH; Fig. 5b). These are not essential for electron transport to NAP (Potter & Cole, 1999) and are absent in the *nap* cluster of *Paracoccus denitrificans* which instead has a gene encoding a small single-helix transmembrane protein, NapE. It is however notable that there are genes encoding structural homologues of NapFGH elsewhere on the *Paracoccus denitrificans* chromosome (see Berks *et al.*, 1995a for a detailed discussion of the NapFGH protein families).

The periplasmic reduction of nitrate to ammonium via the NAP and Nrf systems can also support anaerobic growth in some sulphate-reducing bacteria, for example *Desulfovibrio desulfuricans* and *Sulfurospirillum deleyianum*, studies on which have recently provided X-ray crystal structures of both enzymes (Dias *et al.*, 1999; Einsle *et al.*, 1999). These species thus have a rather flexible respiratory metabolism, enabling them to grow as either sulphate reducers or nitrate reducers (Moura *et al.*, 1997) and they can express multi-haem cytochromes of both the HAO/Nrf family (Fig. 5) and the cytochrome c_3 family to facilitate this (Fig. 3b).

NAP and anaerobic denitrification

In many of the best characterized denitrification systems NAR catalyses the first stage of anaerobic nitrate reduction to nitrite (e.g. *Pseudomonas stutzeri* and *Paracoccus* species). In *Paracoccus pantotrophus* a mutation in the structural genes of the *nar* operon led to the generation of a mutant strain that could de-repress NAP under anaerobic conditions. Consequently it could still grow under anaerobic denitrifying conditions using NAP, rather than NAR, in the first step (Bell *et al.*, 1993). The strain did, however, have a lower specific growth rate and growth yield. Recently, it has become apparent that some *Rhizobium* species (e.g. G179) can express a NAP and that disruption of the *nap* genes is lethal for growth under denitrifying conditions (Bedzyk *et al.*, 1999). Also, in *Rhodobacter sphaeroides* f. sp. *denitrificans*, which can express both NAR and NAP, mutation of NAP is lethal for anaerobic denitrification (Liu *et al.*, 1999). Thus, in these organisms one of the physiological roles of NAP is in anaerobic denitrification. When considered in isolation, the energy coupling of NAR and NAP appear markedly different: $q^+/2e^- = 6$ (NAR) and 4 (NAP) with NADH as electron

donor and 2 (NAR) and 0 (NAP) with succinate as electron donor. However, when considered in the context of the entire denitrification pathway the $q^+/2e^-$ ratio is 24 (NAR) or 22 (NAP) with NADH and 8 (NAR) or 6 (NAP) with succinate. Thus the energetic loss of using NAP rather than NAR is only 8% when NADH is the electron donor to the respiratory system.

Denitrification, nitric oxide reductase and the evolution of oxygen respiration

In many bacteria, the nitrite generated from nitrate respiration can be further reduced in the reactions of denitrification (Berks *et al.*, 1995a; Zumft, 1997) (Fig. 6). In *Paracoccus* species this proceeds via a periplasmic nitrite reductase containing *c* and d_1 haems, an integral membrane NO reductase complex and a periplasmic copper-containing N_2O reductase (Fig. 11). In some denitrifying bacteria the cd_1 nitrite reductase can be substituted by a copper enzyme. There has been one report that *Paracoccus denitrificans* has the genes for both a cytochrome cd_1 and copper enzyme (Hallin & Lindgren, 1999), but this has yet to be confirmed by biochemical studies. Crystal structures of both types of nitrite reductase have been solved recently and have been reviewed in detail elsewhere (Ferguson, 1998; Richardson & Watmough, 1999). Denitrification is widespread in Bacteria (Zumft, 1997), but is also recognized in some Archaea (Volkl *et al.*, 1993) and thus it is likely that it evolved before the last universal ancestor (Castresana & Saraste, 1995).

The nitric oxide reductase (NOR), which catalyses the reaction $2NO + 2e^- + 2H^+ \rightarrow N_2O + H_2O$, is an integral membrane protein and analysis of its primary structure has established that it is a divergent member of the family of respiratory haem-copper oxidases (Saraste & Castresana, 1994; van der Oost *et al.*, 1994) (Fig. 12). Since NO is known to have been abundant on early Earth, this observation suggests that the mitochondrial cytochrome aa_3 oxidase evolved from an ancient nitric oxide reductase. Indeed, haem-copper oxidases possess a low nitric oxide reductase activity and, conversely, nitric oxide reductase possesses a low oxidase activity (Watmough *et al.*, 1999). As the Earth's environment was evolving, some 3 billion years ago, it is likely that oxygen was present at low levels, even before the evolution of oxygen-splitting photosynthesis (Fig. 1). The early oxidases that evolved from NOR would have been likely to have had a high affinity for oxygen. Examples of such high-affinity oxidases may now be found in the cytochrome cbb_3 branch of the currently known haem-copper oxidase family, which is the branch most closely related to the Bacterial NORs (Saraste & Castresana, 1994).

The nitrous oxide reductase is a soluble periplasmic enzyme that binds two distinct copper centres. One, Cu_{cat} , is the site of N_2O reduction whilst the other, Cu_A , is an electron-transfer site that mediates electron transfer between periplasmic electron donors and the Cu_{cat} site (Farrar *et al.*, 1998). Cu_A is a binuclear copper centre

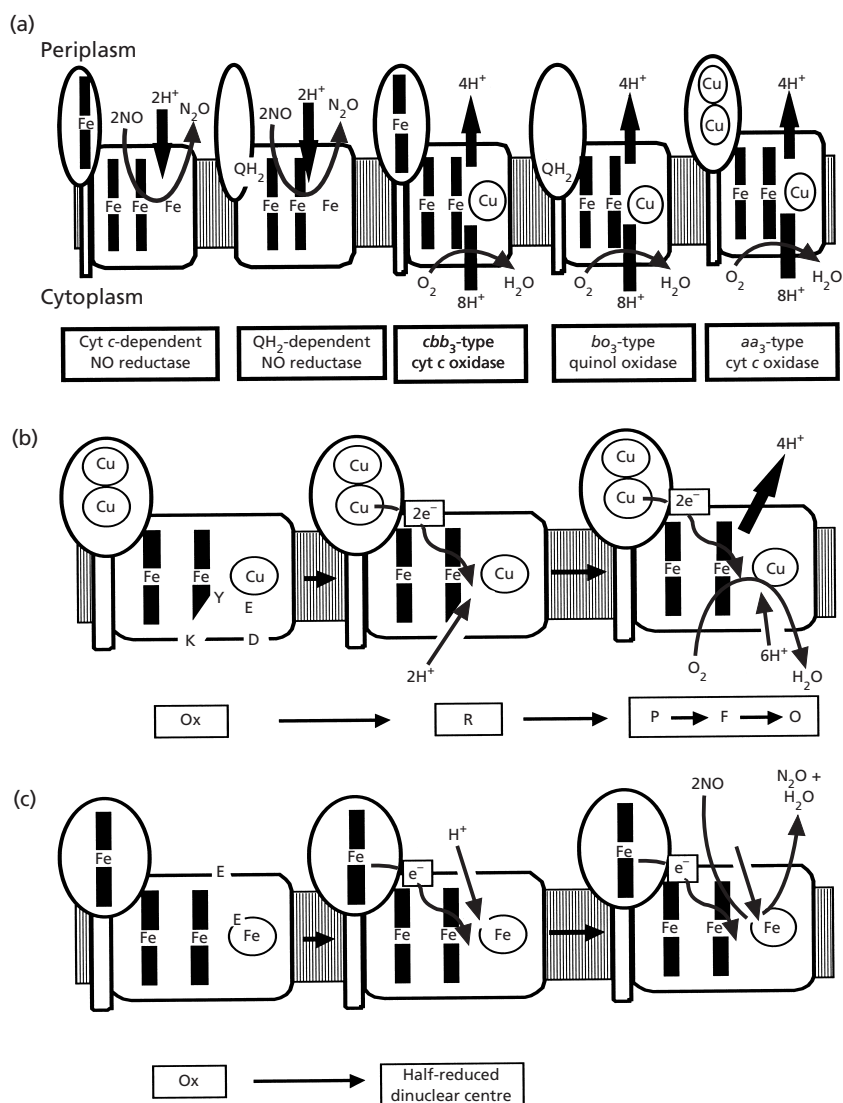

Fig. 12. The haem-copper oxidase family. (a) Organization of the nitric oxide reductases and oxidases of the haem-copper oxidase family. (b) The possible proton channels of the haem-copper oxidases. (c) The possible periplasmic proton channel of NOR.

that lies in a cupredoxin fold. Such a centre is also found in the Bacterial cytochrome *aa*₃ oxidases. Since it is likely that denitrification preceded oxygen respiration, and thus that N₂O reductase existed before oxidases, it would seem that the cytochrome *aa*₃ oxidase evolved as a hybrid enzyme as a result of gene duplication and fusion events involving the *nor* and *nos* genes (van der Oost *et al.*, 1994; Saraste & Castresana, 1994).

The core catalytic subunits of the haem-copper oxidase family comprise 12 transmembrane helices which bind a magnetically isolated electron-transferring haem and dinuclear active site formed by a haem magnetically coupled to a copper ion (Cu_B). Secondary-structure modelling of NOR suggests a similar 12 helical arrangement and similar cofactor-binding properties. Seven conserved histidine residues, responsible for ligating the three redox-active metal centres, can be identified in helices II, VI, VII and X. Each of these histidine residues is conserved in the NorB subunit of NOR which co-purifies as a heterodimer with NorC, a

membrane-anchored mono-haem *c*-type cytochrome. The key difference between NOR and other haem-copper oxidases is the composition of the dinuclear centre which contains non-haem iron (Fe_B) rather than copper (Cu_B) (Fig. 12). It may be that the ancestral enzyme from which NOR and haem-copper oxidases evolved incorporated iron into the dinuclear site because, under the highly reducing conditions of the primordial biosphere, ferrous ions were more readily available than insoluble cuprous ions. Since denitrification preceded aerobic respiration in the biosphere, the primary function of the ancestral oxidase was the reduction of NO. A key step in the evolution of aerobic life on Earth may have then been the substitution of iron by copper in the ancestral oxidase, allowing it to reduce oxygen efficiently. The three histidine residues responsible for ligating Cu_B in oxidases (the 'Cu_B' histidines) are completely conserved in NorB and are likely to be Fe_B ligands. It is well established that Fe(III) prefers different coordination geometry (e.g. octahedral and penta- or hexa-dentate) to Cu(II) (e.g. distorted tetra-

hedral and tetra-dentate). Primary-sequence analysis of NorB reveals four conserved glutamic acid residues (E125, E198, E202, E267; *Paracoccus denitrificans* numbering), located in potential transmembrane helices, that are absent from haem-copper oxidases (Fig. 1). Given that glutamate is frequently found in biological systems as a non-haem Fe ligand, it is plausible that one or more of these conserved glutamates is involved in coordinating Fe_B, along with the three conserved 'Cu_B' histidine ligands. In addition, they may serve to modulate the properties of the catalytic centre leading to differences in the redox potentials of the haem that may in turn influence the catalytic cycle. At present there is little agreement on the catalytic cycle of NOR. An early study on NO reduction in the cytochrome *aa*₃ oxidase suggested the involvement of a [haem-NO NO-Cu_B] intermediate (Brudwig *et al.*, 1980). An analogous [haem-NO NO-Fe_B] intermediate has been forwarded for NOR which then leads to the formation and loss of N₂O, leaving an oxo-bridged species (Girsch & de Vries, 1997; Hendriks *et al.*, 1998). An alternative possibility is the binding of two NO molecules to a coordinately unsaturated Fe_B. This has been observed on the Cu_B of the cytochrome *bo* oxidase (Butler *et al.*, 1997; Watmough *et al.*, 1998) and has the advantage of preventing the formation of a ferrous haem-nitrosyl species which in myoglobins bind NO very tightly (Watmough *et al.*, 1999). One means by which this may be avoided is the low redox potential of the NOR haem of the dinuclear centre, which is around 200 mV lower than that of cytochrome *aa*₃ oxidase (Grönberg *et al.*, 1999).

A second key step in the evolution of aerobic life on Earth may have been the development of proton translocation. Cytochrome *aa*₃ oxidase pumps four protons across the membrane for every O₂ that is reduced to water. Recent high-resolution X-ray crystal structures of cytochrome *aa*₃ oxidase, together with site-specific mutagenesis, have led to the identification of amino acid residues that form the so-called D and K channels which are important in the delivery of protons from the cytoplasm to the dinuclear centre (Fig. 12b) (Konstantinov *et al.*, 1997). However, these residues are absent from NOR and, furthermore, it has been demonstrated that in chromatophores of *Rhodobacter capsulatus* there is no generation of membrane potential when electrons were fed into the electron-transfer system at the level of periplasmic *c*-type cytochrome (Bell *et al.*, 1992). This observation rules out both a cytoplasmic site of nitric oxide reduction (i.e. with protons taken from the cytoplasm) and a proton-pumping activity of the nitric oxide reductase. This suggests that NOR is not a proton pump and takes catalytic protons from the periplasm. Hence, for a NO-reducing primordial enzyme to evolve into a cytochrome *c* oxidase it had not only to evolve a Cu-containing dinuclear centre, but also a proton-pumping mechanism. It seems probable that some conserved glutamic acid residues present in periplasmic loop regions and putative transmembrane helices in NOR but absent in other

cytochrome *c* oxidases play a role in proton movements. Little is currently known about the mechanism of proton output from cytochrome *aa*₃ and cytochrome *bo* oxidases, and it is possible that the ancient proton-input channel used to move protons from the periplasm to the di-nuclear centre in NOR evolved into the proton-output channel. Comparative studies on proton input in NOR and proton output in cytochrome *aa*₃ oxidase may prove informative in this respect.

Two classes of nitric oxide reductase

Analysis of the amino acid sequences of NORs in the current databases reveals that there are two NOR branches. In one group, which includes the enzymes of the denitrifiers *Paracoccus denitrificans* and *Pseudomonas stutzeri*, the catalytic subunit, NorB, is predicted to comprise 12 transmembrane helices and the *norB* gene is adjacent to the *norC* gene which encodes a membrane-anchored mono-haem *c*-type cytochrome. This cytochrome mediates electron transfer between the proton-motive cytochrome *bc*₁ complex and NorB. In the second class of NORs, for example in the denitrifier *Ralstonia eutropha* (Cramm *et al.*, 1997), the *norB* gene is always found in isolation; *norC* is not present. In these cases the NorB protein is predicted to have a C-terminal extension which folds to give two extra transmembrane helices linked by a globular region in the periplasm. It has been suggested that this extension serves as a functional substitute for NorC (Cramm *et al.*, 1997), with a possibility being that it serves as a direct quinol dehydrogenase (Cramm *et al.*, 1999) so that, by analogy to oxidases, there are cytochrome *c*-dependent and quinol-dependent systems. This would lead to a cytochrome *bc*₁-complex-independent route for electron transport and so the NorC-dependent and quinol-dependent NORs would have different coupling efficiencies. The q⁺/e⁻ for the NorC-dependent system would be 6 and 2 with NADH and succinate as electron donors, respectively, but it would be 4 and 0 for the quinol-dependent NOR. These differences in energy coupling then resemble the situation described earlier for the membrane-bound and periplasmic nitrate reductases. In the case of *Ralstonia eutropha*, which actually has genes for two of the NorC-independent NOR systems, there will then be a small price to pay in energy coupling during denitrification with the q⁺/e⁻ ratio being 22 and 6 with NADH and succinate as electron donor, compared to 24 and 8 when the cyt *bc*₁-linked NorC-dependent system operates in *Paracoccus denitrificans*. It is not clear which class of NOR evolved first and it would thus be informative to characterize some NORs from denitrifying Archaea, which has not yet been done.

Multiple physiological roles for NOR

Although NOR classically plays a role in anaerobic denitrification in Bacteria, it is clear that it may be operative under some aerobic conditions, participating in the process of aerobic denitrification. As discussed earlier, bacteria can use a variety of means to dispose of

excess reductant generated during oxidative metabolism of reduced carbon substrates, and one mechanism available to many denitrifying bacteria is the process of nitrification coupled to aerobic denitrification (Robertson & Kuenen, 1990). In autotrophs such as *Nitrosomonas europaea*, ammonia oxidation to hydroxylamine consumes one molecule of QH_2 (Fig. 5a). Hydroxylamine oxidation to nitrite utilizes H_2O as an oxygen donor and is catalysed by the periplasmic hydroxylamine oxidoreductase, generating four reducing equivalents (Fig. 5a). Two of these are used to reduce a molecule of ubiquinone, to regenerate QH_2 for the ammonia monooxygenase, and two are consumed in oxygen reduction by the protonmotive cytochrome oxidase. However, in heterotrophs ammonia oxidation cannot support lithoautotrophic growth. One reason may be that oxidation of NH_2OH by a periplasmic hydroxylamine oxidase requires oxygen rather than water (Moir *et al.*, 1996; Richardson *et al.*, 1998) and thus yields only two reducing equivalents. These can be transferred to either the nitrite reductase, nitrous oxide reductase or nitric oxide reductase, so that the nitrite produced can ultimately be reduced to N_2 (Fig. 10b). Thus, when the nitrification process of ammonium oxidation to nitrite is coupled to aerobic denitrification, electrons do not reach the denitrification enzymes via the protonmotive cytochrome bc_1 complex and periplasmic electron transfer is uncoupled. Heterotrophic nitrification coupled to denitrification then provides a poorly coupled pathway for removing reductant from the quinol pool. This poor coupling is, importantly, contributed by the absence of proton pumping in NOR.

In addition to providing a key step in the pathway of denitrification, *norB* genes can be identified in the genome sequences of a number of non-denitrifying bacteria, including pathogenic species such as *Mycobacterium avium* and *Neisseria* species and also in the photosynthetic cyanobacterium *Synechocystis*. In these bacteria, NOR may provide a means of removing cytotoxic NO produced by community bacteria or macrophages as part of the host's defence system. It is notable that in many of these bacteria, the NOR expressed is the NorC-independent type, which could provide an uncoupled route of quinol oxidation to facilitate more rapid turn over of NO at high Δp .

Concluding remarks

The evolution of respiratory diversity and flexibility in prokaryotes has made a major contribution to the ability of these microbes to colonize a wide range of the Earth's environments and adapt rapidly to changes within an environment. The field of bacterial respiration provides challenges to physiologists, molecular biologists and biochemists working in environmental, biotechnological, and medical microbiology. There is a continued need to understand the means by which organisms with a flexible respiratory system can modulate gene expression in response to changes in the environment, which can include for example the sensing of oxygen, nitrate or nitric oxide. There is major

potential for exploring respiratory processes in biotechnology, in fields of bioremediation (Lovley, 1995) and development of biosensors (Aylott *et al.*, 1997). The systems themselves provide a rich source of material that can be studied using spectroscopy and structural biology to understand in more detail the fundamentals of bioenergetics at the level of an individual protein, an integrated electron-transport system or the whole cell. Finally, as the genomes of many pathogenic prokaryotes emerge with increasing frequency, there arises a need to understand the implication of the genetic capacity that many of these have for respiratory flexibility in terms of survival and colonization both inside and outside the host.

Acknowledgements

I would like to thank all of my colleagues, past and present, who have contributed to the research arising from my laboratories which is discussed in this review and to the BBSRC, Wellcome Trust, Royal Society and CEC for financial support. I am grateful to Ben Berks, Stephen Spiro and Nick Watmough for helpful discussions, to Stuart Ferguson and Baz Jackson for inspiration and to Andrea Blanchflower for her patience and love.

References

- Aylott, J. W., Richardson, D. J. & Russell, D. A. (1997). Optical sensing of nitrate using a sol-gel immobilised nitrate reductase. *Analyst* **122**, 77–80.
- Bamford, V., Dobbin, P. S., Richardson, D. J. & Hemmings, A. M. (1999). Open conformation of a flavocytochrome c_3 fumarate reductase. *Nat Struct Biol* **6**, 1104–1107.
- Bedzyk, L., Wang, T. & Ye, R. W. (1999). The periplasmic nitrate reductase in *Pseudomonas* sp. strain G-179 catalyzes the first step of denitrification. *J Bacteriol* **181**, 2802–2806.
- Beliaev, A. S. & Saffarini, D. A. (1998). *Shewanella putrefaciens* *mtrB* encodes an outer membrane protein required for Fe(III) and Mn(IV) reduction. *J Bacteriol* **180**, 6292–6297.
- Bell, L. C., Richardson, D. J. & Ferguson, S. J. (1990). Periplasmic and membrane-bound respiratory nitrate reductases in *Thiosphaera pantotropha*: the periplasmic enzyme catalyzes the first step in aerobic denitrification. *FEBS Lett* **265**, 85–87.
- Bell, L. C., Richardson, D. J. & Ferguson, S. J. (1992). Identification of nitric oxide reductase activity in *Rhodobacter capsulatus*: the electron-transport pathway can either use or bypass both cytochrome c_2 and the cytochrome bc_1 complex. *J Gen Microbiol* **138**, 437–443.
- Bennett, B., Benson, N., McEwan, A. G. & Bray, R. C. (1994a). Multiple states of the molybdenum centre of dimethylsulphoxide reductase from *Rhodobacter capsulatus* revealed by EPR spectroscopy. *Eur J Biochem* **225**, 321–331.
- Bennett, B., Berks, B. C., Ferguson, S. J., Thomson, A. J. & Richardson, D. J. (1994b). Mo(V) electron paramagnetic resonance signals from the periplasmic nitrate reductase of *Thiosphaera pantotropha*. *Eur J Biochem* **226**, 789–798.
- Bennett, B., Charnock, J. M., Sears, H. J., Berks, B. C., Thomson, A. J., Ferguson, S. J., Garner, C. D. & Richardson, D. J. (1996). Structural investigation of the molybdenum site of the periplasmic nitrate reductase from *Thiosphaera pantotropha* by X-ray absorption spectroscopy. *Biochem J* **317**, 557–563.

- Bergmann, D. J., Arciero, D. M. & Hooper, A. B. (1994). Organization of the *hao* gene cluster of *Nitrosomonas europaea*: genes for two tetraheme *c* cytochromes. *J Bacteriol* **176**, 3148–3153.
- Berks, B. C., Ferguson, S. J., Moir, J. W. & Richardson, D. J. (1995a). Enzymes and associated electron transport systems that catalyse the respiratory reduction of nitrogen oxides and oxyanions. *Biochim Biophys Acta* **1232**, 97–173.
- Berks, B. C., Page, M. D., Richardson, D. J., Reilly, A., Cavill, A., Outen, F. & Ferguson, S. J. (1995b). Sequence analysis of subunits of the membrane-bound nitrate reductase from a denitrifying bacterium: the integral membrane subunit provides a prototype for the dihaem electron-carrying arm of a redox loop. *Mol Microbiol* **15**, 319–331.
- Berks, B. C., Richardson, D. J., Reilly, A., Willis, A. C. & Ferguson, S. J. (1995c). The *napEDABC* gene cluster encoding the periplasmic nitrate reductase system of *Thiosphaera pantotropha*. *Biochem J* **309**, 983–992.
- Blattner, F. R., Plunkett, G., III, Bloch, C. A. & 14 other authors (1997). The complete genome sequence of *Escherichia coli* K-12. *Science* **277**, 1453–1474.
- Boyington, J. C., Gladyshev, V. N., Khangulov, S. V., Stadtman, T. C. & Sun, P. D. (1997). Crystal structure of formate dehydrogenase H: catalysis involving Mo, molybdopterin, selenocysteine, and an Fe₄S₄ cluster. *Science* **275**, 1305–1308.
- Brudwig, G. W., Steven, T. H. & Chan, S. I. (1980). Reactions of nitric oxide with cytochrome *c* oxidase. *Biochemistry* **19**, 5275–5285.
- Buc, J., Santini, C. L., Giordani, R., Czjzek, M., Wu, L. F. & Giordano, G. (1999). Enzymatic and physiological properties of the tungsten-substituted molybdenum TMAO reductase from *Escherichia coli*. *Mol Microbiol* **32**, 159–168.
- Bult, C. J., White, O., Olsen, G. J. & 20 other authors (1996). Complete genome sequence of the methanogenic archaeon, *Methanococcus jannaschii*. *Science* **273**, 1058–1073.
- Butler, C. S., Seward, H. E., Greenwood, C. & Thomson, A. J. (1997). Fast cytochrome *bo* from *Escherichia coli* binds two molecules of nitric oxide at Cu_B. *Biochemistry* **36**, 16259–16266.
- Butler, C. S., Charnock, J. M., Bennett, B. & 8 other authors (1999). Models for molybdenum coordination during the catalytic cycle of periplasmic nitrate reductase from *Paracoccus denitrificans* derived from EPR and EXAFS spectroscopy. *Biochemistry* **38**, 9000–9012.
- Castillo, F., Dobao, M. M., Reyes, F., Blasco, R., Roldán, M. D., Gavira, M., Caballero, F. J., Moreno-Vivián, C. & Martínez-Luque, M. (1996). Molecular and regulatory properties of the nitrate reducing systems of *Rhodobacter*. *Curr Microbiol* **33**, 341–346.
- Castresana, J. & Moreira, D. (1999). Respiratory chains in the last common ancestor of living organisms. *J Mol Evol* **49**, 453–460.
- Castresana, J. & Saraste, M. (1995). Evolution of energetic metabolism: the respiration-early hypothesis. *Trends Biochem Sci* **20**, 443–448.
- Cole, S. T., Brosch, R., Parkhill, J. & 39 other authors (1998). Deciphering the biology of *Mycobacterium tuberculosis* from the complete genome sequence. *Nature* **393**, 537–544.
- Craig, J. A. & Holm, R. H. (1989). Reduction of nitrate to nitrite by molybdenum mediated atom transfer: a nitrate reductase analogue reaction system. *J Am Chem Soc* **111**, 2111–2115.
- Cramm, R., Siddiqui, R. A. & Friedrich, B. (1997). Two isofunctional nitric oxide reductases in *Alcaligenes eutrophus* H16. *J Bacteriol* **179**, 6769–6777.
- Cramm, R., Pohlmann, A. & Friedrich, B. (1999). Purification and characterisation of a single component nitric oxide reductase from *Ralstonia eutropha* H16. *FEBS Lett* **460**, 6–10.
- Czjzek, M., Dos Santos, J. P., Pommier, J., Giordano, G., Mejean, V. & Haser, R. (1998). Crystal structure of oxidized trimethylamine N-oxide reductase from *Shewanella massilia* at 2.5 Å resolution. *J Mol Biol* **284**, 435–447.
- Darwin, A. J. & Stewart, V. (1995). Nitrate and nitrite regulation of the Fnr-dependent *aeg-46.5* promoter of *Escherichia coli* K-12 is mediated by competition between homologous response regulators (NarL and NarP) for a common DNA-binding site. *J Mol Biol* **251**, 15–29.
- Darwin, A., Hussain, H., Griffiths, L., Grove, J., Sambongi, Y., Busby, S. & Cole, J. (1993). Regulation and sequence of the structural gene for cytochrome *c*₅₅₂ from *Escherichia coli*: not a hexahaem but a 50 kDa tetrahaem nitrite reductase. *Mol Microbiol* **9**, 1255–1265.
- Dias, J. M., Than, M. E., Humm, A. & 10 other authors (1999). Crystal structure of the first dissimilatory nitrate reductase at 1.9 Å solved by MAD methods. *Structure* **7**, 65–79.
- D'mello, R., Hill, S. & Poole, R. K. (1996). The cytochrome *bd* quinol oxidase in *Escherichia coli* has an extremely high oxygen affinity and two oxygen-binding haems: implications for regulation of activity *in vivo* by oxygen inhibition. *Microbiology* **142**, 755–763.
- Dobbin, P., Powell, A. K., McEwan, A. G. & Richardson, D. J. (1995). The influence of chelating agents on the dissimilatory reduction of iron(III) by *Shewanella putrefaciens*. *Biometals* **8**, 163–173.
- Dobbin, P. S., Requena Burmeister, L. M., Heath S. L., Powell, A. K., McEwan, A. G. & Richardson, D. J. (1996a). The influence of chelating agents upon the dissimilatory reduction of Fe(III) by *Shewanella putrefaciens*. II. Oxo- and hydroxo-bridged polynuclear Fe(III) complexes. *Biometals* **9**, 291–301.
- Dobbin, P. S., Warren, L. H., Cook, N. J., McEwan, A. G., Powell, A. K. & Richardson, D. J. (1996b). Dissimilatory iron(III) reduction by *Rhodobacter capsulatus*. *Microbiology* **142**, 765–774.
- Dobbin, P. S., Butt, J. N., Powell, A. K., Reid, G. A. & Richardson, D. J. (1999). Characterization of a flavocytochrome that is induced during the anaerobic respiration of Fe(III) by *Shewanella frigidimarina* NCIMB 400. *Biochem J* **342**, 439–448.
- Dolfing, J. (1990). Reductive dechlorination of 3-chlorobenzoate is coupled to ATP production and growth in an anaerobic bacterium, strain DCB-1. *Arch Microbiol* **153**, 264–266.
- Einsle, O., Messerschmidt, A., Stach, P., Bourenkov, G. P., Bartunik, H. D., Huber, R. & Kroneck, P. M. (1999). Structure of cytochrome *c* nitrite reductase. *Nature* **400**, 476–480.
- Farrar, J. A., Zumft, W. G. & Thomson, A. J. (1998). Cu_A and Cu_Z are variants of the electron transfer center in nitrous oxide reductase. *Proc Natl Acad Sci USA* **95**, 9891–9896.
- Ferguson, S. J. (1998). Nitrogen cycle enzymology. *Curr Opin Chem Biol* **2**, 182–193.
- Ferguson, S. J., Jackson, J. B. & McEwan, A. G. (1987). Anaerobic respiration in the *Rhodospirillaceae*. *FEMS Microbiol Rev* **46**, 117–143.
- Field, S., Dobbin, P. S., Cheesman, M. R., Watmough, N. J., Thomson, A. J. & Richardson, D. J. (2000). Purification and magneto-optical characterisation of membrane-bound multi-heme cytochromes from *Shewanella frigidimarina*. *J Biol Chem* **275**, in press.

- Flanagan, D. A., Gregory, L. G., Carter, J. P., Karakas-Sen, A., Richardson, D. J. & Spiro, S. (1999). Detection of genes for periplasmic nitrate reductase in nitrate respiring bacteria and in community DNA. *FEMS Microbiol Lett* **177**, 263–270.
- Fleischmann, R. D., Adams, M. D., White, O. & 37 other authors (1995). Whole-genome random sequencing and assembly of *Haemophilus influenzae* Rd. *Science* **269**, 496–512.
- de Gier, J. W., Lubben, M., Reijnders, W. N., Tipker, C. A., Slotboom, D. J., van Spanning, R. J., Stouthamer, A. H. & van der Oost, J. (1994). The terminal oxidases of *Paracoccus denitrificans*. *Mol Microbiol* **13**, 183–196.
- Girsch, P. & de Vries, S. (1997). Purification and initial kinetic and spectroscopic characterization of NO reductase from *Paracoccus denitrificans*. *Biochim Biophys Acta* **1318**, 202–216.
- Gold, T. (1992). The deep, hot biosphere. *Proc Natl Acad Sci USA* **89**, 6045–6049.
- Grönberg, K. L. C., Roldan, M. D., Prior, L., Butland, G., Cheesman, M. R., Richardson, D. J., Spiro, S., Thomson, A. J. & Watmough, N. J. (1999). A low redox potential haem in the dinuclear centre of bacterial nitric oxide reductase: implications for the evolution of energy-conserving haem-copper oxidases. *Biochemistry* **38**, 13780–13786.
- Hallin, S. & Lindgren, P. E. (1999). PCR detection of genes encoding nitrite reductase in denitrifying bacteria. *Appl Environ Microbiol* **65**, 1652–1657.
- Hamilton, W. A. (1998). Bioenergetics of sulphate-reducing bacteria in relation to their environmental impact. *Biodegradation* **9**, 201–212.
- Hendriks, J., Warne, A., Gohlke, U., Haltia, T., Ludovici, C., Lubben, M. & Saraste, M. (1998). The active site of the bacterial nitric oxide reductase is a dinuclear iron center. *Biochemistry* **37**, 13102–13109.
- Hensel, M., Hinsley, A. P., Nikolaus, T., Sawers, G. & Berks, B. C. (1999). The genetic basis of tetrathionate respiration in *Salmonella typhimurium*. *Mol Microbiol* **32**, 275–287.
- Hilton, J. C., Temple, C. A. & Rajagopalan, K. V. (1999). Redesign of *Rhodobacter sphaeroides* dimethyl sulfoxide reductase: enhancement of adenosine N1-oxide reductase activity. *J Biol Chem* **274**, 8428–8436.
- Hoehn, G. T. & Clark, V. L. (1992). Isolation and nucleotide sequence of the gene (*aniA*) encoding the major anaerobically induced outer membrane protein of *Neisseria gonorrhoeae*. *Infect Immun* **60**, 4695–4703.
- Householder, T. C., Belli, W. A., Lissenden, S., Cole, J. A. & Clark, V. L. (1999). *cis*- and *trans*-acting elements involved in regulation of *aniA*, the gene encoding the major anaerobically induced outer membrane protein in *Neisseria gonorrhoeae*. *J Bacteriol* **181**, 541–551.
- Hussain, H., Grove, J., Griffiths, L., Busby, S. & Cole, J. (1994). A seven gene operon essential for formate-dependent nitrite reduction to ammonia by enteric bacteria. *Mol Microbiol* **12**, 153–163.
- Igarashi, N., Moriyama, H., Fujiwara, T., Fukumori, Y. & Tanaka, N. (1997). The 2.8 Å structure of hydroxylamine oxidoreductase from a nitrifying chemoautotrophic bacterium, *Nitrosomonas europaea*. *Nat Struct Biol* **4**, 276–284.
- Iverson, T. M., Arciero, D. M., Hsu, B. T., Logan, M. S., Hooper, A. B. & Rees, D. C. (1998). Heme packing motifs revealed by the crystal structure of the tetra-heme cytochrome *c554* from *Nitrosomonas europaea*. *Nat Struct Biol* **5**, 1005–1012.
- Jones, M., Richardson, D. J., McEwan, A. G., Jackson, J. B. & Ferguson, S. J. (1990). *In vivo* redox poisoning of the cyclic electron transport system of *Rhodobacter capsulatus* and the effects of the auxilliary oxidants nitrate, nitrous oxide and trimethylamine N-oxide as revealed by multiple short flash excitation. *Biochim Biophys Acta* **1017**, 209–216.
- Jungst, A., Wakabayashi, S., Matsubara, H. & Zumft, W. G. (1991). The *nirSTBM* region coding for cytochrome *cd*₁-dependent nitrite respiration of *Pseudomonas stutzeri* consists of a cluster of mono-, di-, and tetraheme proteins. *FEBS Lett* **279**, 205–209.
- Khangulov, S. V., Gladyshev, V. N., Dismukes, G. C. & Stadtman, T. C. (1998). Selenium-containing formate dehydrogenase H from *Escherichia coli*: a molybdopterin enzyme that catalyzes formate oxidation without oxygen transfer. *Biochemistry* **37**, 3518–3528.
- Kisker, C., Schindelin, H. & Rees, D. C. (1997). Molybdenum-cofactor-containing enzymes: structure and mechanism. *Annu Rev Biochem* **66**, 233–267.
- Klenk, H. P., Clayton, R. A., Tomb, J. F. & 48 other authors (1997). The complete genome sequence of the hyperthermophilic sulphate-reducing archaeon *Archaeoglobus fulgidus*. *Nature* **390**, 364–370.
- Konstantinov, A. A., Siletsky, S., Mitchell, D., Kaulen, A. & Gennis, R. B. (1997). The roles of the two proton input channels in cytochrome *c* oxidase from *Rhodobacter sphaeroides* probed by the effects of site-directed mutations on time-resolved electrogenic intraprotein proton transfer. *Proc Natl Acad Sci USA* **94**, 9085–9090.
- Krafft, T. & Macy, J. M. (1998). Purification and characterization of the respiratory arsenate reductase of *Chrysiogenes arsenatis*. *Eur J Biochem* **255**, 647–653.
- Leys, D., Tsapin, A. S., Neelson, K. H., Meyer, T. E., Cusanovich, M. A. & van Beeumen, J. J. (1999). Structure and mechanism of the flavocytochrome *c* fumarate reductase of *Shewanella putrefaciens* MR-1. *Nat Struct Biol* **6**, 1113–1117.
- Lie, T. J., Godchaux, W. & Leadbetter, E. R. (1999). Sulfonates as terminal electron acceptors for growth of sulfite-reducing bacteria (*Desulfitobacterium* spp.) and sulfate-reducing bacteria: effects of inhibitors of sulfidogenesis. *Appl Environ Microbiol* **65**, 4611–4617.
- Liu, H. P., Takio, S., Satoh, T. & Yamamoto, I. (1999). Involvement in denitrification of the *napKEFDABC* genes encoding the periplasmic nitrate reductase system in the denitrifying phototrophic bacterium *Rhodobacter sphaeroides* f. sp. *denitrificans*. *Biosci Biotechnol Biochem* **63**, 530–536.
- Lloyd, J. R., Cole, J. A. & Macaskie, L. E. (1997). Reduction and removal of heptavalent technetium from solution by *Escherichia coli*. *J Bacteriol* **179**, 2014–2021.
- Lloyd, J. R., Ridley, J., Khizniak, T., Lyalikova, N. N. & Macaskie, L. E. (1999). Reduction of technetium by *Desulfovibrio desulfuricans*: biocatalyst characterization and use in a flowthrough bioreactor. *Appl Environ Microbiol* **65**, 2691–2696.
- Lonergan, D. J., Jenter, H. L., Coates, J. D., Phillips, E. J., Schmidt, T. M. & Lovley, D. R. (1996). Phylogenetic analysis of dissimilatory Fe(III)-reducing bacteria. *J Bacteriol* **178**, 2402–2408.
- Louie, T. M. & Mohn, W. W. (1999). Evidence for a chemiosmotic model of dehalorespiration in *Desulfomonile tiedjei* DCB-1. *J Bacteriol* **181**, 40–46.
- Lovley, D. R. (1991). Dissimilatory Fe(III) and Mn(IV) reduction. *Microbiol Rev* **55**, 259–287.
- Lovley, D. R. (1995). Bioremediation of organic and metal contaminants with dissimilatory metal reduction. *J Ind Microbiol* **14**, 85–93.

- Lovley, D. R. (1997). Microbial Fe(III) reduction in subsurface environments. *FEMS Microbiol Rev* **20**, 305–313.
- Lovley, D. R. & Coates, J. D. (1997). Bioremediation of metal contamination. *Curr Opin Biotechnol* **8**, 285–289.
- Lovley, D. R. & Phillips, E. J. (1992). Reduction of uranium by *Desulfovibrio desulfuricans*. *Appl Environ Microbiol* **58**, 850–856.
- Lovley, D. R., Widman, P. K., Woodward, J. C. & Phillips, E. J. (1993). Reduction of uranium by cytochrome *c3* of *Desulfovibrio vulgaris*. *Appl Environ Microbiol* **59**, 3572–3576.
- Lovley, D. R., Woodward, J. C. & Chapelle, F. H. (1994). Stimulated anoxic biodegradation of aromatic hydrocarbons using Fe(III) ligands. *Nature* **370**, 128–131.
- McAlpine, A. S., McEwan, A. G. & Bailey, S. (1998). The high resolution crystal structure of DMSO reductase in complex with DMSO. *J Mol Biol* **275**, 613–623.
- McEwan, A. G., Cotton, N. P. J., Ferguson, S. J. & Jackson, J. B. (1985). The role of auxiliary oxidants in the maintenance of a balanced redox poise for photosynthesis in bacteria. *Biochim Biophys Acta* **810**, 140–147.
- McKay, D. S., Gibson, E. K., Jr, Thomas-Keppta, K. L., Vali, H., Romanek, C. S., Clemett, S. J., Chillier, X. D. F., Maechling, C. R. & Zare, R. N. (1996). Search for past life on Mars: possible relic biogenic activity in martian meteorite ALH84001. *Science* **273**, 924–930.
- Macy, J. M., Rech, S., Auling, G., Dorsch, M., Stackebrandt, E. & Sly, L. I. (1993). *Thauera selenatis* gen. nov., sp. nov., a member of the beta subclass of *Proteobacteria* with a novel type of anaerobic respiration. *Int J Syst Bacteriol* **43**, 135–142.
- Macy, J. M., Nunan, K., Hagen, K. D., Dixon, D. R., Harbour, P. J., Cahill, M. & Sly, L. I. (1996). *Chrysiogenes arsenatis* gen. nov., sp. nov., a new arsenate-respiring bacterium isolated from gold mine wastewater. *Int J Syst Bacteriol* **46**, 1153–1157.
- Magalon, A., Asso, M., Guigliarelli, B., Rothery, R. A., Bertrand, P., Giordano, G. & Blasco, F. (1998). Molybdenum cofactor properties and [Fe-S] cluster coordination in *Escherichia coli* nitrate reductase A: investigation by site-directed mutagenesis of the conserved his-50 residue in the NarG subunit. *Biochemistry* **37**, 7363–7370.
- Matias, P. M., Coelho, R., Pereira, I. A., Coelho, A. V., Thompson, A. W., Sieker, L. C., Gall, J. L. & Carrondo, M. A. (1999). The primary and three-dimensional structures of a nine-haem cytochrome *c* from *Desulfovibrio desulfuricans* ATCC 27774 reveal a new member of the Hmc family. *Structure Fold Des* **7**, 119–130.
- Moir, J. W., Wehrfritz, J. M., Spiro, S. & Richardson, D. J. (1996). The biochemical characterization of a novel non-haem-iron hydroxylamine oxidase from *Paracoccus denitrificans* GB17. *Biochem J* **319**, 823–827.
- Moura, I., Bursakov, S., Costa, C. & Moura, J. G. (1997). Nitrate and nitrite utilisation in sulfate-reducing bacteria. *Anaerobe* **3**, 279–290.
- Myers, C. R. & Myers, J. M. (1997a). Cloning and sequence of *cymA*, a gene encoding a tetraheme cytochrome *c* required for reduction of iron(III), fumarate, and nitrate by *Shewanella putrefaciens* MR-1. *J Bacteriol* **179**, 1143–1152.
- Myers, C. R. & Myers, J. M. (1997b). Outer membrane cytochromes of *Shewanella putrefaciens* MR-1: spectral analysis, and purification of the 83 kDa *c*-type cytochrome. *Biochim Biophys Acta* **1326**, 307–318.
- Myers, J. M. & Myers, C. R. (1998). Isolation and sequence of *omcA*, a gene encoding a decaheme outer membrane cytochrome *c* of *Shewanella putrefaciens* MR-1, and detection of *omcA* homologs in other strains of *S. putrefaciens*. *Biochim Biophys Acta* **1373**, 237–251.
- Nicholls, D. G. & Ferguson, S. J. (Editors) (1992). *Bioenergetics 2*. London: Academic Press.
- van der Oost, J., de Boer, A. P., de Gier, J. W., Zumft, W. G., Stouthamer, A. H. & van Spanning, R. J. (1994). The heme-copper oxidase family consists of three distinct types of terminal oxidases and is related to nitric oxide reductase. *FEMS Microbiol Lett* **121**, 1–9.
- van de Pas, B. A., Smidt, H., Hagen, W. R., van der Oost, J., Schraa, G., Stams, A. J. & de Vos, W. M. (1999). Purification and molecular characterization of ortho-chlorophenol reductive dehalogenase, a key enzyme of halo-respiration in *Desulfotobacterium dehalogenans*. *J Biol Chem* **274**, 20287–20292.
- Pollock, W. B., Loutfi, M., Bruschi, M., Rapp-Giles, B. J., Wall, J. D. & Voordouw, G. (1991). Cloning, sequencing, and expression of the gene encoding the high-molecular-weight cytochrome *c* from *Desulfovibrio vulgaris* Hildenborough. *J Bacteriol* **173**, 220–228.
- Poole, R. K. & Hill, S. (1997). Respiratory protection of nitrogenase activity in *Azotobacter vinelandii* – roles of the terminal oxidases. *Biosci Rep* **17**, 303–317.
- Potter, L. C. & Cole, J. A. (1999). Essential roles for the products of the *napABCD* genes, but not *napFGH*, in periplasmic nitrate reduction by *Escherichia coli* K-12. *Biochem J* **344**, 69–76.
- Potter, L. C., Millington, P., Griffiths, L., Thomas, G. H. & Cole, J. A. (1999). Competition between *Escherichia coli* strains expressing either a periplasmic or a membrane-bound nitrate reductase: does Nap confer a selective advantage during nitrate-limited growth? *Biochem J* **344**, 77–84.
- Preisig, O., Anthamatten, D. & Hennecke, H. (1993). Genes for a microaerobically induced oxidase complex in *Bradyrhizobium japonicum* are essential for a nitrogen-fixing endosymbiosis. *Proc Natl Acad Sci USA* **90**, 3309–3313.
- Qian, Y. & Tabita, F. R. (1998). Expression of *glnB* and a *glnB*-like gene (*glnK*) in a ribulose biphosphate carboxylase/oxygenase-deficient mutant of *Rhodobacter sphaeroides*. *J Bacteriol* **180**, 4644–4649.
- Rabin, R. S. & Stewart, V. (1993). Dual response regulators (NarL and NarP) interact with dual sensors (NarX and NarQ) to control nitrate- and nitrite-regulated gene expression in *Escherichia coli* K-12. *J Bacteriol* **175**, 3259–3268.
- Reyes, F., Gavira, M., Castillo, F. & Moreno-Vivian, C. (1998). Periplasmic nitrate-reducing system of the phototrophic bacterium *Rhodobacter sphaeroides* DSM 158: transcriptional and mutational analysis of the *napKEFDABC* gene cluster. *Biochem J* **331**, 897–904.
- Richardson, D. & Ferguson S. J. (1992). The influence of carbon substrate on the activity of the periplasmic nitrate reductase in aerobically grown *Thiosphaera pantotropha*. *Arch Microbiol* **157**, 535–537.
- Richardson, D. J. & Watmough, N. J. (1999). Inorganic nitrogen metabolism in bacteria. *Curr Opin Chem Biol* **3**, 207–219.
- Richardson, D. J., King, G. F., Kelly, D. J., McEwan, A. G., Ferguson, S. J. & Jackson, J. B. (1988). The role of auxiliary oxidants in maintaining redox balance during phototrophic growth of *Rhodobacter capsulatus* on propionate or butyrate. *Arch Microbiol* **150**, 131–137.
- Richardson, D. J., Wehrfritz, J. M., Keech, A. & 10 other authors (1998). The diversity of redox proteins involved in bacterial heterotrophic nitrification and aerobic denitrification. *Biochem Soc Trans* **26**, 401–408.

- Robertson, L. A. & Kuenen, J. G. (1990).** Combined heterotrophic nitrification and aerobic denitrification in *Thiosphaera pantotropha* and other bacteria. *Antonie Leeuwenhoek* **57**, 139–152.
- Roldan, M. D., Sears, H. J., Cheesman, M. R., Ferguson, S. J., Thomson, A. J., Berks, B. C. & Richardson, D. J. (1998).** Spectroscopic characterization of a novel multiheme *c*-type cytochrome widely implicated in bacterial electron transport. *J Biol Chem* **273**, 28785–28790.
- Rossi, M., Pollock, W. B., Reij, M. W., Keon, R. G., Fu, R. & Voordouw, G. (1993).** The *hmc* operon of *Desulfovibrio vulgaris* subsp. *vulgaris* Hildenborough encodes a potential transmembrane redox protein complex. *J Bacteriol* **175**, 4699–4711.
- Rothery, R. A., Blasco, F., Magalon, A., Asso, M. & Weiner, J. H. (1999).** The hemes of *Escherichia coli* nitrate reductase A (NarGHI): potentiometric effects of inhibitor binding to NarI. *Biochemistry* **38**, 12747–12757.
- Saraste, M. (1994).** Structure and evolution of cytochrome oxidase. *Antonie Leeuwenhoek* **65**, 285–287.
- Saraste, M. & Castresana, J. (1994).** Cytochrome oxidase evolved by tinkering with denitrification enzymes. *FEBS Lett* **341**, 1–4.
- Schafer, G., Purschke, W. & Schmidt, C. L. (1996).** On the origin of respiration: electron transport proteins from archaea to man. *FEMS Microbiol Rev* **18**, 173–188.
- Schindelin, H., Kisker, C., Hilton, J., Rajagopalan, K. V. & Rees, D. C. (1996).** Crystal structure of DMSO reductase: redox-linked changes in molybdopterin coordination. *Science* **272**, 1615–1621.
- Schroder, I., Rech, S., Krafft, T. & Macy, J. M. (1997).** Purification and characterization of the selenate reductase from *Thauera selenatis*. *J Biol Chem* **272**, 23765–23768.
- Sears, H., Ferguson S. J., Richardson D. J. & Spiro S. (1993).** The identification of a periplasmic nitrate reductase in *Paracoccus denitrificans*. *FEMS Microbiol Lett* **113**, 107–112.
- Sears, H. J., Little, P. J., Richardson, D. J., Berks, B. C., Spiro, S. & Ferguson, S. J. (1997a).** Identification of an assimilatory nitrate reductase in mutants of *Paracoccus denitrificans* GB17 deficient on nitrate respiration. *Arch Microbiol* **167**, 61–66.
- Sears, H., Spiro, S. & Richardson, D. J. (1997b).** Effect of carbon substrate and aeration on nitrate reduction and expression of the periplasmic and membrane-bound nitrate reductases in carbon-limited continuous cultures of *Paracoccus denitrificans*. *Microbiology* **143**, 3767–3774.
- Shaw, A. L., Hochkoeppler, A., Bonora, P., Zannoni, D., Hanson, G. R. & McEwan, A. G. (1999).** Characterization of DorC from *Rhodobacter capsulatus*, a *c*-type cytochrome involved in electron transfer to dimethyl sulfoxide reductase. *J Biol Chem* **274**, 9911–9914.
- Siddiqui, R. A., Warnecke-Eberz, U., Hengsberger, A., Schneider, B., Kostka, S. & Friedrich, B. (1993).** Structure and function of a periplasmic nitrate reductase in *Alcaligenes eutrophus* H16. *J Bacteriol* **175**, 5867–5876.
- Simoes, P., Matias, P. M., Morais, J., Wilson, K., Dauter, Z. & Carrondo, M. A. (1998).** Refinement of the three dimensional structure of cytochromes c_3 from *Desulfovibrio vulgaris* Hildenberg at 1.67 angstrom resolution and *Desulfovibrio desulfuricans* ATCC 27772 at 1.6 angstrom resolution. *Inorg Chim Acta* **273**, 213–224.
- Spector, M. P., Garcia del Portillo, F., Bearson, S. M. D., Mahmud, A., Magut, M., Finlay, B. B., Dougan, G., Foster, J. W. & Pallen, M. J. (1999).** The *rpoS*-dependent starvation-stress response locus *stiA* encodes a nitrate reductase (*narZYWV*) required for carbon-starvation-inducible thermotolerance and acid tolerance in *Salmonella typhimurium*. *Microbiology* **145**, 3035–3045.
- Sugio, T., Hirose, T., Ye, L. Z. & Tano, T. (1992).** Purification and some properties of sulfite:ferric ion oxidoreductase from *Thiobacillus ferrooxidans*. *J Bacteriol* **174**, 4189–4192.
- Takamiya, K., Arata, H., Shioi, Y. & Doi, M. (1988).** Restoration of the optimal redox state for the photosynthetic electron transport system by auxilliary oxidants in an aerobic photosynthetic bacterium, *Erythrobacter* sp. OCh 114. *Biochim Biophys Acta* **935**, 26–33.
- Tanapongpipat, S., Reid, E., Cole, J. A. & Croke, H. (1998).** Transcriptional control and essential roles of the *Escherichia coli* *ccm* gene products in formate-dependent nitrite reduction and cytochrome *c* synthesis. *Biochem J* **334**, 355–365.
- Taylor, P., Pealing, S., Reid, G. A., Chapman, S. K. & Walkinshaw, M. D. (1999).** Structural and mechanistic mapping of a unique fumarate reductase. *Nat Struct Biol* **6**, 1108–1112.
- Thauer, R. K. (1998).** Biochemistry of methanogens: a tribute to Marjory Stephenson. *Microbiology* **144**, 2377–2406.
- Tomb, J. F., White, O., Kerlavage, A. R. & 41 other authors (1997).** The complete genome sequence of the gastric pathogen *Helicobacter pylori*. *Nature* **388**, 539–547.
- Vargas, M., Kashefi, K., Blunt-Harris, E. L. & Lovley, D. R. (1998).** Microbiological evidence for Fe(III) reduction on early Earth. *Nature* **395**, 65–67.
- Volkl, P., Huber, R., Drobner, E., Rachel, R., Burggraf, S., Trincone, A. & Stetter, K. O. (1993).** *Pyrobaculum aerophilum* sp. nov., a novel nitrate-reducing hyperthermophilic archaeum. *Appl Environ Microbiol* **59**, 2918–2926.
- Wang, H., Tseng, C. P. & Gunsalus, R. P. (1999).** The *napF* and *narG* nitrate reductase operons in *Escherichia coli* are differentially expressed in response to submicromolar concentrations of nitrate but not nitrite. *J Bacteriol* **181**, 5303–5308.
- Watmough, N. J., Cheesman, M. R., Butler, C. S., Little, R. H., Greenwood, C. & Thomson, A. J. (1998).** The dinuclear center of cytochrome bo_3 from *Escherichia coli*. *J Bioenerg Biomembr* **30**, 55–62.
- Watmough, N. J., Butland, G., Cheesman, M. R., Moir, J. W., Richardson, D. J. & Spiro, S. (1999).** Nitric oxide in bacteria: synthesis and consumption. *Biochim Biophys Acta* **1411**, 456–474.
- Way, S. S., Sallustio, S., Magliozzo, R. S. & Goldberg, M. B. (1999).** Impact of either increased or decreased levels of cytochrome *bd* expression on *Shigella flexinera* virulence. *J Bacteriol* **181**, 1229–1237.
- Zumft, W. G. (1997).** Cell biology and molecular basis of denitrification. *Microbiol Mol Biol Rev* **61**, 533–616.