

Transcription-modulatory activities of differentially spliced cDNAs encoding the E2 protein of human papillomavirus type 16

Nathalie Alloul and Levana Sherman

Department of Human Microbiology, Sackler School of Medicine, Tel-Aviv University, Tel-Aviv 69978, Israel

Human papillomavirus (HPV) type 16 expresses a variety of alternatively spliced polycistronic mRNAs encoding the E2 transcription-regulatory protein. These mRNAs initiate at the p97 promoter and contain the 880/2708 (a-type), 880/2581 (a'-type) and 226/2708 (d-type) splice sites upstream from the E2 open reading frame (ORF). Recent studies investigating the translational capacities of partial cDNAs representing three of these mRNAs indicated their abilities to function in E2 protein translation, although at different efficiencies. In the present study, the transcription-regulatory activities of the E2 cDNAs towards the virus long control region (LCR) have been examined. LCR regulation was evaluated in transient transfection assays by using the chloramphenicol acetyltransferase reporter gene linked to the HPV-16 LCR. Transfections were carried out into fibroblast (Cf2Th) and epithelial (C33A) cell lines. It is shown that all three E2 cDNAs transrepressed the virus LCR in a dose-dependent manner. Transrepression was mainly dependent on the function of the E2 ORF and was abolished or markedly reduced by premature termination or truncation of the E2 ORF. Transrepression activities exhibited by the various E2 cDNAs correlated with the previously defined efficiencies of E2 protein translation from the respective templates. The truncated E2 cDNAs exhibited variable low regulatory activities that correlated with the activities of the 5' ORFs contained in each cDNA. The E6I and E1C ORFs transactivated the virus LCR whereas the E6IV cDNA transrepressed LCR activity. Thus, the 5' ORFs contribute in different manners to the overall activities of the polycistronic cDNAs.

Introduction

Human papillomavirus (HPV) type 16 is the prototype of the oncogenic group of HPVs, which are associated with genital pre-cancerous lesions and carcinomas (de Villiers, 1989; zur Hausen, 1996). The viral genome is actively transcribed in tumours and in cells transfected with HPV-16 DNA (Smotkin & Wettstein, 1986; Shirasawa *et al.*, 1988; Smotkin *et al.*, 1989; Doorbar *et al.*, 1990; Rohlf *et al.*, 1991; Sherman *et al.*, 1992; Sherman & Alloul, 1992). Early transcription of the viral genes initiates at the p97 promoter, located in the 3' end of the virus long control region (LCR) (Smotkin & Wettstein 1986; Smotkin *et al.*, 1989). Complex mRNA splicing generates the authentic templates for translation of the viral proteins. The major virus factor controlling HPV transcription is the E2

protein (reviewed by McBride *et al.*, 1991; Thierry, 1996). E2 binds as a dimer to the cognate DNA sequence ACCGNN-NNCGGT, which is present in four copies at conserved relative positions in the LCRs of all genital HPVs (McBride *et al.*, 1991; Thierry, 1996).

The function of the HPV E2 protein in regulation of the LCR is the subject of some controversy. Initial studies have demonstrated that E2 activates transcription from the virus LCR (Phelps & Howley, 1987; Cripe *et al.*, 1987; Ushikai *et al.*, 1994; Bouvard *et al.*, 1994). However, other studies have shown that in the genital HPVs, E2 represses rather than transactivates transcription from the virus early promoters (Romanczuk *et al.*, 1990; Bernard *et al.*, 1989; Tan *et al.*, 1992). The repression of transcription involves binding of the full-length E2 protein to E2-binding sites close to the TATA box and apparently functions by preventing binding of transcription factors required for formation of the transcription-initiation complex (Bernard *et al.*, 1989; Romanczuk *et al.*,

Author for correspondence: Levana Sherman.
Fax +972 3 6409160. e-mail lsherman@post.tau.ac.il

1990; Tan *et al.*, 1992, 1994). Additional studies on the regulation of the E6 promoters of HPV-16 and HPV-18 by the homologous E2 proteins have suggested that the regulatory effect may depend on the level of E2, transactivating at a lower level and transrepressing as the level increases (Bouvard *et al.*, 1994; Ushikai *et al.*, 1994; Steger & Corbach, 1997). Little is known about the mechanisms involved in the control of E2 protein expression. The HPV E2 protein is encoded by viral mRNAs containing multiple open reading frames (ORFs). HPV-16 expresses a variety of alternatively spliced mRNAs containing the full-length E2 ORF as an internal ORF. The majority of the E2 transcripts initiate at the p97 promoter and thus contain the E2 ORF connected via alternative splice sites to variable upstream 5' ORFs (Sherman & Alloul, 1992). Recent translation experiments in cell-free systems and COS cells indicated that cDNAs containing the full-length E2 ORF and the related upstream ORFs of mRNA species a (880/2708), a' (880/2581) and d (226/2708) function in translation of the E2 protein, although at different efficiencies. Efficiency of translation from the d-type template was three and four times higher than that from the a- and a'-type templates, respectively. Expression from all three polycistronic templates was lower than that from a synthetic monocistronic template. Further investigation of the translation capacity of the upstream ORFs showed that the a- and a'-type templates serve for translation of E6I and mainly E7 proteins, while the d-type template functions in translation of the E6 variant, E6IV (Alloul & Sherman, 1999). Since previous studies have established the ability of E6I and E7 proteins to function as transcriptional regulators (Shirasawa *et al.*, 1994; Armstrong & Roman, 1997), the coordinated translation of these proteins with E2 could possibly affect E2-mediated transcriptional regulation of the virus LCR.

In the present study, we were interested in investigating whether the differential level of E2 protein translation from the d-, a- and a'-type mRNAs has functional consequences for the transcriptional activity of the virus LCR and whether co-translation of proteins encoded by the upstream ORFs affects E2-mediated regulation of the virus LCR.

The transcriptional activities of the polycistronic cDNAs were evaluated in transient transfection assays by using the chloramphenicol acetyltransferase (CAT) reporter gene linked to the HPV-16 LCR. The data obtained indicated that differentially spliced, E2-encoding cDNAs exerted variable levels of transrepression on the virus LCR. Transrepression activity was mainly due to E2 protein expression and correlated with the previously defined efficiencies of E2 protein translation. Low transcription-regulatory activities were also exerted by some of the 5' ORF cDNAs. The E6IV splice variant cDNA transrepressed the virus LCR while the E1C cDNA and, to a less extent, the E6I cDNA transactivated the virus LCR, thus contributing in different manners to the overall regulatory activities of the polycistronic cDNAs.

The results suggest that differential splicing within RNAs

encoding E2 may regulate transcription from the virus LCR by modulating the levels of E2 protein translation and by carrying accessory ORFs for putative proteins that possess variable transcription-regulatory activities.

Methods

■ **Plasmids.** Construction of cDNAs spanning the E2 ORF and the related upstream ORFs of HPV-16 mRNA species a, a' and d (Fig. 1) was described previously (Alloul & Sherman, 1999). To produce isogenic mutant clones containing premature termination codons in the E2 ORF, the E2 cDNAs cloned into the pJS55 vector were cut with *Bst*XI, which cuts at position 2891, blunt-ended with T4 DNA polymerase and self-ligated, thus creating a stop codon at position 2984.

To obtain truncated cDNAs spanning the 5' ORFs of the d- and a'-type cDNAs (Fig. 1), the respective E2 cDNAs cloned into pJS55 were cut with *Bst*XI and *Hind*III (which cuts in the vector sequence downstream of the cDNA) to excise the E2 ORF (between nucleotides 2891 and 3852). The resulting plasmids were blunt-ended and self-ligated to obtain the truncated d- and a'-type cDNAs (Tr-d and Tr-a'). The E6I-E7-E1C-E2 (a') cDNA was cut with *Nco*I (which cuts at position 863) and *Hind*III and then ligated to the E1C ORF fragment excised from the pJS55 E1C cDNA clone (A. Gluchov, N. Alloul and L. Sherman, unpublished data), which had been cut with the same enzymes.

pJS55 vectors carrying monocistronic cDNAs spanning the individual ORFs E2, E6I, E6IV, E7 and E1C were described previously (Alloul & Sherman, 1999; Shally *et al.*, 1996; Sherman & Schlegel, 1996). P. G. Fuchs (University of Cologne, Cologne, Germany) kindly provided the plasmid LCR-CAT containing the HPV-16 regulatory sequences between nucleotides 7008 and 123, upstream of the CAT gene.

■ **Cell cultures and transfections.** Cells were grown in Dulbecco's modified Eagle's medium (DMEM) supplemented with 10% foetal calf serum. Transient transfections were performed by a modified calcium phosphate method, as described previously (Sherman & Schlegel, 1996). Canine foetal thymus (Cf2Th) cells were kindly provided by S. A. Aaronson (Mount Sinai Institute, New York, USA). C33-A carcinoma cells were kindly provided by R. Schlegel (Georgetown University, Washington, DC, USA).

■ **CAT assays.** Cells were plated into 9 cm dishes and transfected with 2 (Cf2Th) or 6 μ g (C33A) of the CAT reporter plasmid and 0.5–5 μ g of the expression plasmids. The amount of transfected DNA was kept constant in all experiments by the addition of the parental vector DNA (pJS55). Cells were harvested 48 h later and CAT activity was assayed by the method of Gorman *et al.* (1982) as described previously (Sherman *et al.*, 1997). The percentage of chloramphenicol acetylation was quantified by scanning the silica gel sheet on a Bio-Rad phosphorimager. CAT activity was normalized for transfection efficiency by co-transfecting a constant amount (1 μ g) of a CMV- β -galactosidase plasmid (β -gal) into all tissue culture dishes. The amount of β -galactosidase activity was determined by using *O*-nitrophenyl β -D-galactopyranoside (ONPG) as a colorimetric substrate. Each experiment was performed at least three times.

■ **RNA isolation and quantification.** Transfections for mRNA quantification were carried out simultaneously with the transfections for CAT analyses. Total RNA was isolated from the 9 cm dishes 48 h post-transfection by using the RNA/DNA protein reagent (TRI REAGENT) (Molecular Research Center) according to the manufacturer's instructions.

The amount of RNA and parameters for semi-quantitative PCR analysis of RNA were predetermined for each primer pair (Zhao *et al.*,

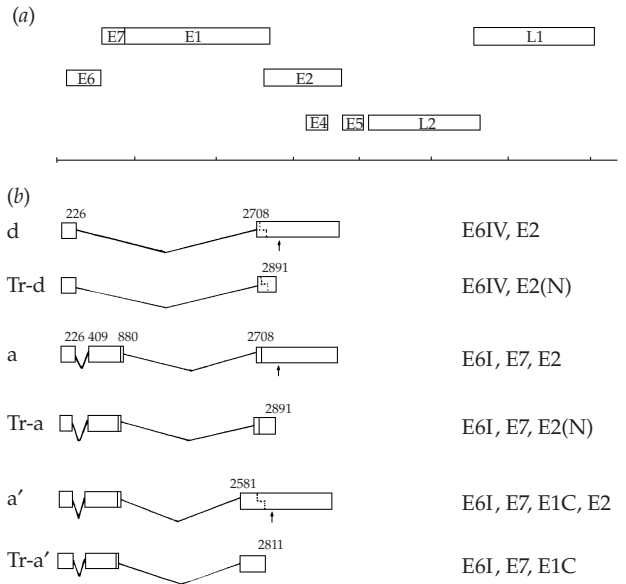

Fig. 1. Structure of HPV-16 genome and cDNAs containing the full-length or the truncated E2 ORF. (a) Diagram of the genome of HPV-16 and positions of the ORFs. (b) Structure of the cDNAs of mRNA species d, a and a' encoding the E2 protein of HPV-16. The corresponding truncated (Tr) cDNAs spanning the 5' ORFs of each mRNA are depicted below. Positions of common splice sites are shown only once. The open boxes represent potential coding regions. Borders of overlapping ORFs are shown by dotted lines. The coding capacity of each cDNA is indicated on the right.

1995; Lupetti *et al.*, 1996). Reverse transcription was carried out as described previously (Sherman & Alloul, 1992) in a total volume of 50 μ l containing 1 μ g total RNA (which was first denatured at 65 $^{\circ}$ C for 10 min and immediately chilled) and 0.3 μ g/ μ l oligo(dT) (20-mer) as an antisense primer. The reaction mixture was incubated at 42 $^{\circ}$ C for 60 min. Following inactivation at 95 $^{\circ}$ C for 5 min, 5–10 μ l of the cDNA product was used as a template for a PCR with the individual primer pairs as described previously (Sherman & Alloul, 1992).

Primer pairs for detection of the various mRNAs were pJS55 969-s (5' TCCTGGGCAACGTGC 3') and the HPV-16 2930-as primer, which detects the a- and d-type mRNAs, or the HPV-16 2684-as primer, which detects the a'-type mRNA. PCRs were carried out for 28 cycles of 1 min at 94 $^{\circ}$ C, 1 min at 55 $^{\circ}$ C and 1 min at 72 $^{\circ}$ C. Detection of the human β -actin mRNA was carried out with the primers actin-s (5' GAGGAATTCTGAGACCTTCAACACCCC 3') and actin-as (5' GAGAAGCTTGTGGCCATCTCTTGCTCGAAGTC 3') with the same parameters as described above for 18 cycles.

Results

HPV-16 E2 expression from a monocistronic construct negatively regulates the HPV-16 LCR

As the first step in investigating the transcription-regulatory activity of the E2-encoding polycistronic cDNAs (Fig. 1) towards the homologous virus LCR, experiments were carried out to determine the activity of the E2 protein expressed from a synthetic monocistronic cDNA. Four different fibroblast and epithelial cell lines were initially evaluated for their ability to support basal transcription from the HPV-16 LCR–CAT

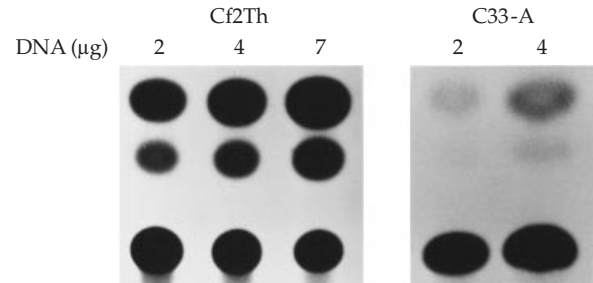

Fig. 2. Basal CAT activity in fibroblast and epithelial cell lines transfected with the HPV-16 LCR–CAT. Transfections were carried out with 2–7 μ g of the CAT reporter plasmid. Amounts of transfected DNA were standardized by addition of pJS55. CAT activity was determined in cell extracts prepared 48 h post-transfection. Autoradiographs of representative CAT assays with extracts from Cf2Th and C33A cells are shown.

reporter plasmid. The fibroblast cell lines Cf2Th (canine) and 3T3-NIH (murine) showed high levels of CAT activity that were dependent on the amount of DNA transfected (Fig. 2 and data not shown). Activity of the CAT reporter plasmid was significantly lower in human epithelial C33A cells derived from a cervical carcinoma (Fig. 2). Minimal CAT activity was also detected (data not shown) in the human keratinocyte cell line HaCaT (Boukamp *et al.*, 1988). Consequently, the transcription-regulatory effects of the various cDNAs were evaluated in the Cf2Th and C33A cell lines.

Transfection of increasing amounts of the monocistronic pJS55-E2 plasmid (0.5–5 μ g) into Cf2Th cells with 2 μ g of the reporter LCR–CAT plasmid caused a significant reduction in the basal CAT activity (Fig. 3a). Repression of the virus LCR was dose-dependent, stronger with larger amounts of the E2 plasmid. This repression was not observed in cells transfected with equivalent amounts of the vector pJS55. To verify the specificity of the E2-mediated repression of the HPV-16 LCR, we compared the effects of the E2 and vector plasmids on two heterologous promoters (Fig. 3b). CAT activities expressed from the early SV40 and CMV promoters were similar in cells co-transfected with the E2 plasmid or vector plasmid, supporting the specificity of E2-mediated repression of the virus LCR. Co-transfection experiments carried out in C33A cells generated the same results (data not shown).

E2 ORF-containing polycistronic cDNAs repress the virus LCR

Our previous studies have shown variable levels of translation of the E2 protein from differentially spliced polycistronic cDNAs representing the a-, a'- and d-type mRNAs of HPV-16 (Fig. 1) (Alloul & Sherman, 1999). To determine whether this has functional consequences, the overall transcription-regulatory activities of the polycistronic cDNAs towards the virus LCR were examined. Activities of the polycistronic cDNAs were compared with that of the synthetic E2 monocistronic control.

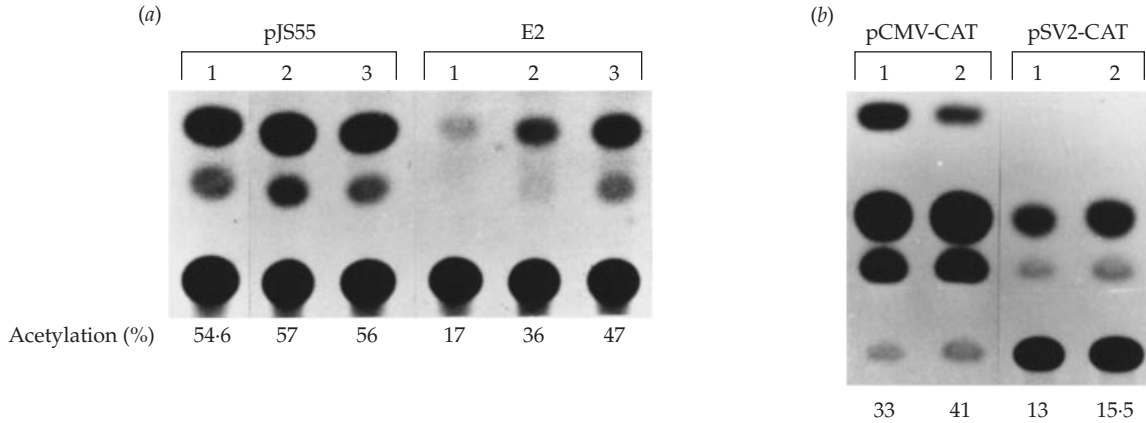

Fig. 3. Transcription-regulatory activity of HPV-16 E2 protein expressed from a monocistronic expression vector towards the homologous virus LCR (a) and towards heterologous promoters (b). Cf2Th cells were transfected with constant amounts of the LCR-CAT plasmid and various amounts of the monocistronic E2 expression vector. Total amounts of DNA were standardized by addition of pJS55. (a) CAT assays with extracts from cells transfected with 2 µg LCR-CAT plasmid and 2 (lanes 1), 1 (2) or 0.5 µg (3) of the E2 expression plasmid (E2) or vector pJS55 as indicated. (b) CAT assays with extracts from cells transfected with 1 µg of the indicated CAT reporter vectors and 2 µg of the E2 expression plasmid (lanes 1) or vector pJS55 (lanes 2). The normalized mean percentages of acetylation are shown at the bottom in (a) and (b).

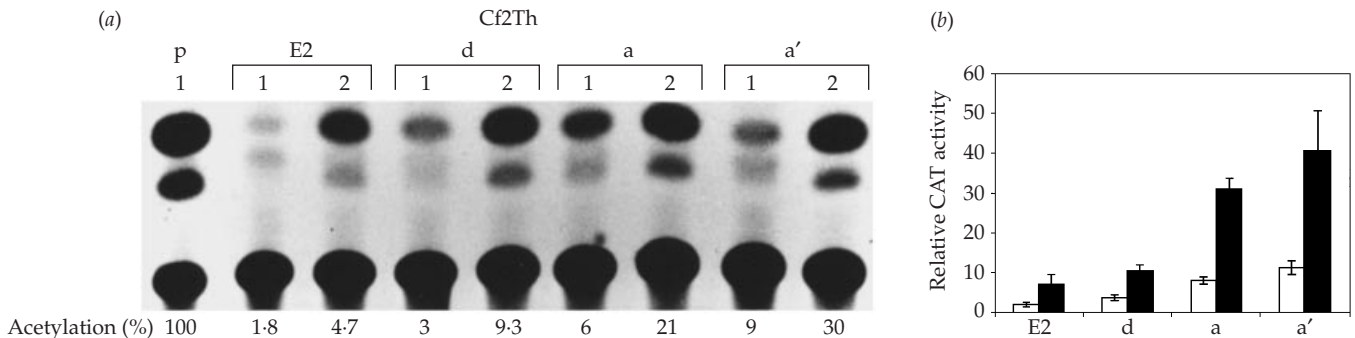

Fig. 4. Dose-dependent transcription-regulatory activities of monocistronic and polycistronic cDNAs encoding the E2 protein. (a) Transfections were carried out into Cf2Th and C33A cells. The polycistronic cDNAs (d, a and a') were transfected at molar amounts equivalent to 2 (lanes 1) and 0.5 µg (lanes 2) of the monocistronic pJS55-E2 plasmid (E2) together with 2 µg (Cf2Th) or 6 µg (C33A) of the LCR-CAT plasmid and 1 µg of the β-gal plasmid. A representative CAT assay with extracts from Cf2Th cells is shown. p, Control cells transfected with 2 µg pJS55 and 2 µg LCR-CAT plasmid. The normalized mean percentages of acetylation are shown at the bottom. (b) Mean relative CAT activities (percentages of control extract activity) obtained after transfection of 2 (open bars) or 0.5 µg (filled bars) E2 expression vector in three independent experiments in Cf2Th cells with standard deviations.

Transfections were carried out with various amounts of DNA that represented molar equivalents of 0.5–5 µg of the E2 monocistronic control. The results shown in Fig. 4, and additional experiments, indicated that all three E2 cDNAs exerted strong repression activity on the virus LCR, although at lower levels than that exhibited by equivalent amounts of the monocistronic E2 expression vector, pJS55-E2 (Fig. 4a, b). The bicistronic E6IV-E2 (d-type) cDNA showed the strongest repression activity. The polycistronic E6I-E7-E2 (a-type) and E6I-E7-E1C-E2 (a'-type) cDNAs showed similar repression activities, with somewhat stronger activity for the a-type cDNA (Fig. 4a, b). The repression activity was dose-dependent for each of the cDNA expression vectors, as described above

for the E2 monocistronic control. The same order of repression was obtained with quantities of the various E2 cDNAs between 0.5 and 5 µg (Fig. 4a, b; data not shown). This order of repression activities of the E2 cDNAs was also observed in C33A epithelial cells transfected with the same amounts of DNA (data not shown).

Repression of the HPV-16 LCR by the E2-encoding cDNAs is mainly due to E2 ORF function

The results described above indicated variable levels of transrepression from the monocistronic and polycistronic E2 cDNAs, which could be the result of the differences described previously in translation efficiency of E2 protein

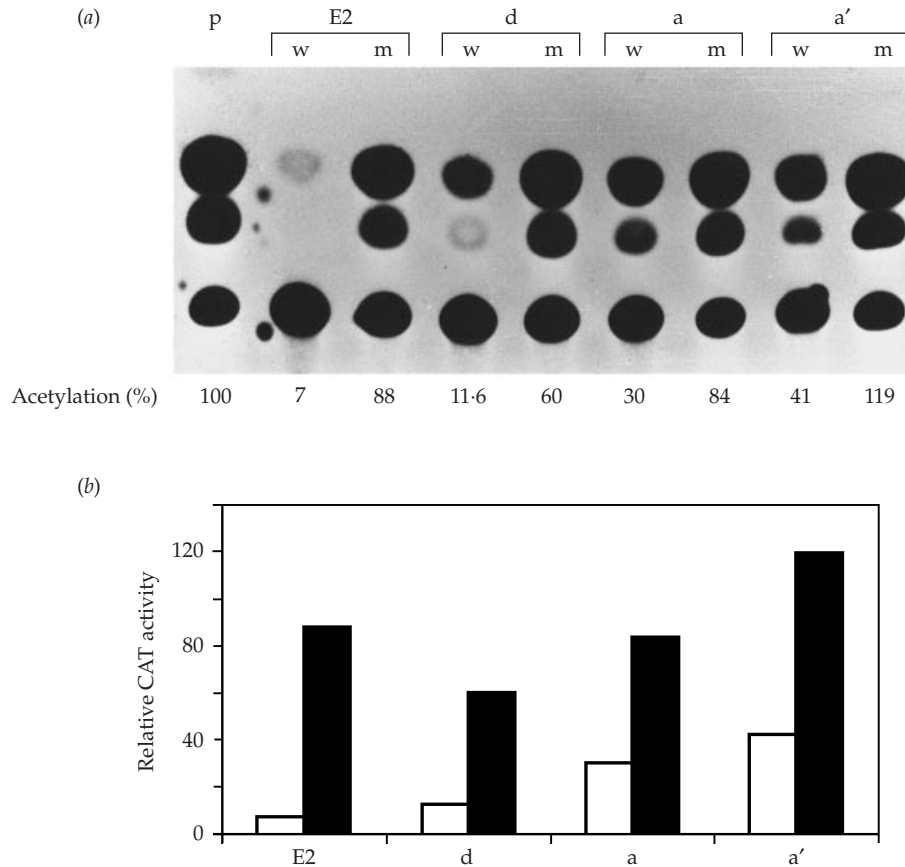

Fig. 5. Transcription-regulatory activities of the a-, a'- and d-type E2 cDNAs and the respective mutant cDNAs towards the HPV-16 LCR. Transfections were carried out into Cf2Th cells with 2 μ g of each cDNA expression plasmid and 2 μ g LCR-CAT plasmid as described in the legend to Fig. 3. Parallel transfections were carried out with the mutant E2 cDNAs (m) and the related 'wild-type' cDNAs (w). (a) CAT activities obtained in a representative assay. p, Control cells transfected with 2 μ g pS55 and 2 μ g LCR-CAT plasmid. The normalized mean percentages of acetylation are shown at the bottom.

(b) Densitometric analysis of the data shown in (a), showing data from 'wild-type' (open bars) and mutant (filled bars) cDNAs.

from the respective cDNAs (Alloul & Sherman, 1999). To establish whether activity of the E2-encoding cDNAs in LCR regulation is indeed due to E2 expression and activity, we assessed the regulatory activities of cDNAs containing a premature termination codon in the 5' end of the E2 ORF. The E2 termination mutants were previously shown to be impaired in E2 protein translation (Alloul & Sherman, 1999). Co-transfection experiments with the mutant cDNAs were carried out simultaneously with transfections with the related wild-type E2 cDNAs (Fig. 5). Results of these comparative assays indicated a significantly reduced or completely abolished transrepression activity of the mutant cDNAs, strongly suggesting a major role for E2 protein translation from all three cDNAs in the cDNA-mediated repression of the LCR.

To exclude the possibility that the differences observed in levels of repression brought about by the various cDNAs are the result of different levels of transcription from the respective cDNAs or different mRNA stabilities, transfected cultures were examined for mRNA levels by a semi-quantitative RT-PCR procedure (Zhao *et al.*, 1995; Lupetti *et al.*, 1996).

Fig. 6 shows the results obtained from quantitative mRNA comparisons in cells transfected with equimolar amounts of the various E2 cDNA vectors. The amount of the RT-PCR product correlated with the amount of transfected cDNA (Fig. 6a) and was at similar levels in cells transfected with molar equivalents of the various E2 cDNAs (Fig. 6b), further supporting the conclusion that the differences observed in the transcription-repression activities of the d-, a- and a'-type cDNAs were due, at least in part, to differences in the efficiency of translation of the E2 protein from the respective cDNAs.

Transcription-regulatory activities of the 5' ORFs

The assays of CAT activity in cells co-transfected with the mutant d- and a'-type cDNAs described above indicated small regulatory effects towards the virus LCR that could result from activities of the 5' ORF-encoded proteins.

To dissect the transcription-regulatory effects of the 5' ORFs, isogenic expression vectors containing truncated cDNAs that span the 5' ORF region (E2-truncated cDNAs) of

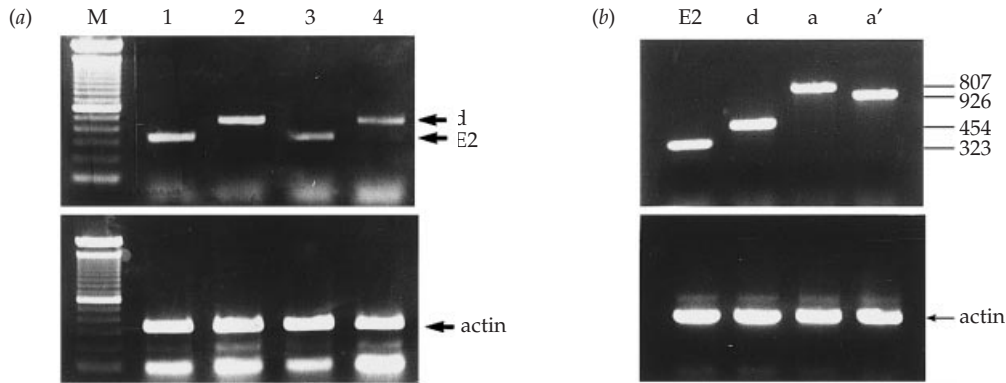

Fig. 6. Levels of mRNA transcription from the various E2 cDNA vectors determined by RT-PCR. Total RNA (1 µg) prepared from cells transfected with different amounts of the E2 cDNAs was applied to the RT-PCR. PCR products were analysed on 1.4% agarose gels stained with ethidium bromide. (a) RT-PCR products obtained from cells transfected with 2 (lanes 1, 2) or 0.5 µg (lanes 3, 4) of the E2 (lanes 1, 3) or d-type cDNA (lanes 2, 4). Arrows indicate the positions of the PCR products. RT-PCR products of the β -actin mRNA in the same samples are shown below. M, DNA markers. (b) RT-PCR products from cells transfected with 2 µg of the indicated cDNAs with primers targeting the individual mRNAs expressed from the transfected cDNAs or the β -actin mRNA (below).

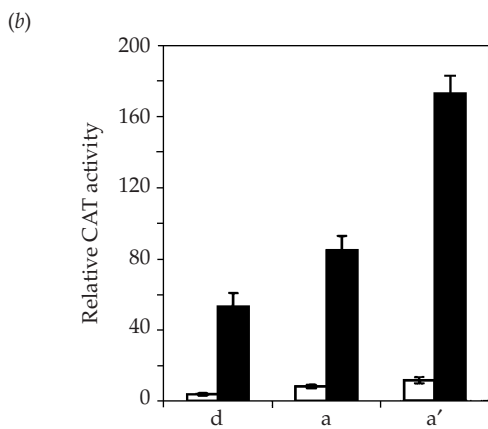
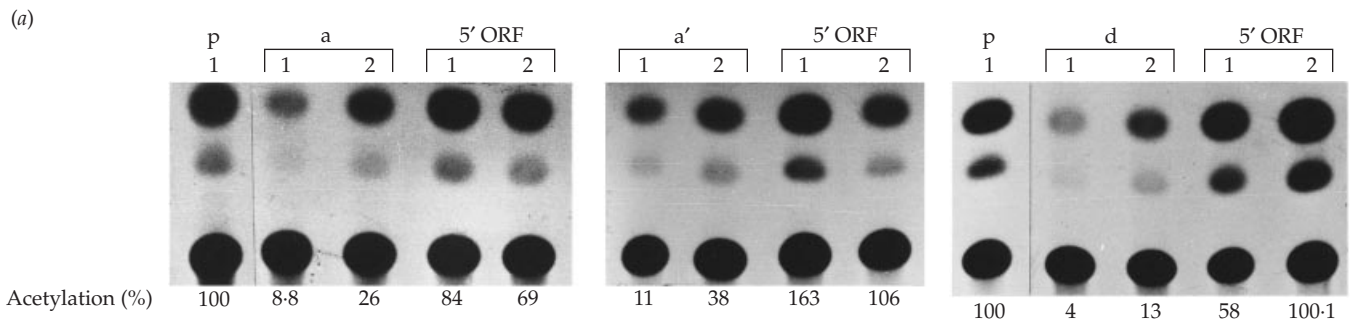

Fig. 7. Transcription-regulatory activities of the a-, a'- and d-type cDNAs and the related E2-truncated cDNAs (5' ORF cDNAs) towards the HPV-16 LCR. Cf2Th cells were transfected with 2 µg (lanes 1) or 0.5 µg (lanes 2) of the indicated plasmids and 2 µg LCR-CAT reporter plasmid. (a) CAT activities of representative assays with the indicated cDNAs. p, Control cells transfected with 2 µg pJS55 and 2 µg LCR-CAT plasmid. The normalized mean percentages of acetylation are shown at the bottom. (b) Mean relative CAT activities with standard deviations obtained from full-length (open bars) or truncated (filled bars) cDNAs in three independent experiments. Values obtained from the transfection of 2 µg of the cDNAs are shown.

mRNA species a, a' and d, as well as vectors carrying each of the individual ORFs contained in the respective cDNAs, were evaluated for the presence of dose-dependent transcription-regulatory effects towards the virus LCR.

Comparing the activities of the E2-truncated cDNAs with those of the E2-containing cDNAs showed marked differences in the regulatory activities (Fig. 7). These were exhibited in

Cf2Th and C33A cells. The d-type truncated cDNA, E6IV-E2(N), like the related E2-containing cDNA (E6IV-E2), showed negative regulatory activity towards the virus LCR. However, this activity was much lower than that exhibited by the E2 ORF-containing cDNA (10 times lower) (Fig. 7a, b). Repression by the truncated d-type cDNA was dose-dependent, increasing with larger amounts of the plasmid. These results

putative E1C protein and that repression of the virus LCR mediated by the a'-type cDNA probably resulted from the E2 gene product, which overrides the positive transcription-regulatory activities of the accessory E1C and possibly E6I proteins.

Discussion

The E2 protein of HPVs plays an important role both in virus replication and in regulation of virus gene transcription (McBride *et al.*, 1991; Thierry, 1996). Transcriptional modulation of the virus LCR by the E2 protein appears to depend on the level of E2 protein (Bouvard *et al.*, 1994; Ushikai *et al.*, 1994; Steger & Corbach, 1997; Stubenrauch & Pfister, 1994; Stubenrauch *et al.*, 1996).

We showed previously that HPV-16 expresses a variety of alternatively spliced polycistronic mRNAs that encode the E2 protein from an internal ORF (Sherman & Alloul, 1992). Further studies on the translational capacities of species a, a' and d indicated different efficiencies of E2 translation from the respective templates. Expression from all three polycistronic templates was lower than that obtained from a synthetic monocistronic control containing the E2 ORF (Alloul & Sherman, 1999). Although transcripts that contain the E2 ORF as the first 5' ORF have not been identified previously, evidence for the existence of promoters within the E7 ORF that could potentially initiate transcription of E2-encoding transcripts has been provided (Higgins *et al.*, 1992; Hemstrom Nilsson *et al.*, 1996; Bohm *et al.*, 1993).

In the present study, we wished to establish the importance of differential splicing within the E2-encoding mRNAs with respect to the function of E2 as a transcriptional regulator. In the first part of this study, we analysed the ability of the various E2 cDNAs to regulate transcription from the virus LCR. We showed that expression of monocistronic as well as polycistronic E2-encoding cDNAs from an SV40-based vector (pJS55) transrepressed the virus LCR in a dose-dependent manner. Transrepression was observed with a range of amounts of transfected DNA (0.5–5 µg). Similar amounts of DNA of CMV-based expression plasmids encoding the E2 proteins of HPV-8 (Stubenrauch & Pfister, 1994; Stubenrauch *et al.*, 1996) and HPV-18 (Steger & Corbach, 1997) were also reported to transrepress the homologous virus LCRs.

Transrepression activity was specific for the virus LCR and was exhibited in different cell types including Cf2Th and C33A cells, respectively of fibroblast and epithelial origin.

Co-transfection of equimolar amounts of the E2 polycistronic cDNAs with the LCR–CAT reporter resulted in different levels of transrepression of the virus LCR. Data obtained from functional analyses of related cDNAs bearing mutations in, or truncation of, the E2 ORF indicated that transrepression was due principally to E2 expression.

Specific activities of the polycistronic cDNA in transrepression were lower than that exhibited by the monocistronic

cDNA and correlated with the previously defined activities of the respective cDNAs in translation of the E2 protein. These results support the functional relevance of alternative splicing in E2-mediated regulation of the virus LCR.

Alternative splicing within the E2-encoding mRNAs not only affects the translation efficiency of the E2 ORF but also dictates the organization of the preceding ORFs. The results of this study showed that cDNAs carrying the 5' ORF regions of species a' and d retained some transregulatory activities towards the virus LCR.

Further analyses of the transcription-regulatory activities of cDNAs containing the individual ORFs expressed from the same SV40-based vector showed that the E6IV, E1C and, to a lesser extent, E6I putative accessory proteins, but not the E7 protein, function in transregulation of the virus LCR, either in a positive (E1C and possibly E6I) or a negative (E6IV) manner. Hence, co-expression of the respective proteins from the natural polycistronic mRNAs would either increase or decrease the E2-mediated transrepression of the virus LCR. Co-translation of E6IV or E6I together with E2 protein from the d- and a-type templates, respectively, was demonstrated previously (Alloul & Sherman, 1999).

Despite the fact that translation of E1C protein from the polycistronic a'-type template was not detected previously (Alloul & Sherman, 1999), the data presented herein on the positive regulatory activity of the related mutant cDNA (carrying a mutation in the E2 ORF), or truncated cDNA, support the ability of the a'-type mRNA to function in translation of the E1C splice-variant protein. The inability to detect the protein could result from low levels of expression and/or instability of the protein.

The data presented in this study on the ability of the E1C cDNA to reduce E2-mediated transrepression are consistent with previous observations showing that an E1 polypeptide spanning the C-terminal domain of bovine papillomavirus type 1 (residues 132–605) is able to repress E2-mediated transactivation of the viral p89 promoter (Ferran & McBride, 1998). Further studies of E1C transactivation and modulation of E2 transrepression are needed.

A low transactivation activity, which was dose-dependent over a small range of low doses of transfected DNA, was also previously attributed to the E6I splice variant (Shirasawa *et al.*, 1994). Our data on transactivation with the monocistronic E6I expression plasmid are consistent with E6I acting as a weak transcriptional activator. The inability to detect the transactivation function with the a-type mutated cDNAs (bearing a mutation in or a truncation of the E2 ORF) could be due to differences in the amount of E6I translated from the respective vectors. Quantitative *in vitro* translation analyses indicated that the a- and a'-type vectors served mainly for translation of E7 (Alloul & Sherman, 1999).

The studies reported herein provide evidence that alternative splicing within E2-encoding mRNAs principally affects the function of E2 as a transcriptional regulator by controlling the

levels of E2 translation and, in addition, by defining the organization of the 5' ORFs, thereby enabling the expression of putative accessory proteins that possess different regulatory activities.

E2-encoding mRNAs expressed from circular viral DNA terminate at the early polyadenylation site located downstream from the E5 ORF. Previous studies demonstrated the coordinated translation of E2 and E5 proteins from bicistronic constructs containing the full-length E2 and E5 ORFs of HPV-16 (Johnsen *et al.*, 1995). The E2 cDNAs described in this study lack the sequences downstream from the E2 ORF, including that of the E5 ORF region. Whether E5 is translated together with E2 from the polycistronic mRNAs and whether it affects E2 transregulatory function remains to be established.

It is tempting to speculate that differential splicing, and possibly alternative initiation, of E2-encoding mRNAs serve as mechanisms to control the activity of the p97 promoter during the virus life-cycle. The HPV life-cycle is strictly linked to epithelial differentiation. After infection of basal cells, HPV genomes are maintained as episomes and transcription of the early genes required for cell immortalization, E6–E7, and virus replication, E1 and E2, is directed by the p97 promoter. At this stage, low, transactivating levels of E2 may be required. Upon differentiation, when differentiation-dependent promoters located within the E7 ORF of HPV-16 (Higgins *et al.*, 1992; Hemstrom Nilsson *et al.*, 1996) are activated, high levels of E2 may be needed to suppress further transcription from p97.

Further studies will be needed to establish whether differential splicing and possibly promoter usage by mRNAs encoding E2 are related to cell differentiation and stage of virus replication.

We are grateful to Dr P. G. Fuchs (University of Cologne, Cologne) for kindly providing the HPV-16 LCR–CAT construct. This research was supported, in part, by a grant from the Basic Research Fund, Tel-Aviv University, to L.S. The work was performed in partial fulfilment of the requirements of the PhD degree of N.A., Sackler Faculty of Medicine, Tel-Aviv University, Israel.

References

- Alloul, N. & Sherman, L. (1999).** The E2 protein of human papillomavirus type 16 is translated from a variety of differentially spliced polycistronic mRNAs. *Journal of General Virology* **80**, 29–37.
- Armstrong, D. J. & Roman, A. (1997).** The relative ability of human papillomavirus type 6 and human papillomavirus type 16 E7 proteins to transactivate E2F-responsive elements is promoter- and cell-dependent. *Virology* **239**, 238–246.
- Bernard, B. A., Bailly, C., Lenoir, M. C., Darmon, M., Thierry, F. & Yaniv, M. (1989).** The human papillomavirus type 18 (HPV18) E2 gene product is a repressor of the HPV18 regulatory region in human keratinocytes. *Journal of Virology* **63**, 4317–4324.
- Bohm, S., Wilczynski, S. P., Pfister, H. & Iftner, T. (1993).** The predominant mRNA class in HPV16-infected genital neoplasias does not encode the E6 or the E7 protein. *International Journal of Cancer* **55**, 791–798.
- Boukamp, P., Petrussevska, R. T., Breitkreutz, D., Hornung, J., Markham, A. & Fusenig, N. E. (1988).** Normal keratinization in a spontaneously immortalized aneuploid human keratinocyte cell line. *Journal of Cell Biology* **106**, 761–771.
- Bouvard, V., Storey, A., Pim, D. & Banks, L. (1994).** Characterization of the human papillomavirus E2 protein: evidence of trans-activation and trans-repression in cervical keratinocytes. *EMBO Journal* **13**, 5451–5459.
- Cripe, T. P., Haugen, T. H., Turk, J. P., Tabatabai, F., Schmid, P. G., III, Durst, M., Gissmann, L., Roman, A. & Turek, L. P. (1987).** Transcriptional regulation of the human papillomavirus 16 E6-E7 promoter by a keratinocyte-dependent enhancer, and by viral E2 trans-activator and repressor gene products: implications for cervical carcinogenesis. *EMBO Journal* **6**, 3745–3753.
- de Villiers, E. M. (1989).** Heterogeneity of the human papillomavirus group. *Journal of Virology* **63**, 4898–4903.
- Doorbar, J., Parton, A., Hartley, K., Banks, L., Crook, T., Stanley, M. & Crawford, L. (1990).** Detection of novel splicing patterns in a HPV16-containing keratinocyte cell line. *Virology* **178**, 254–262.
- Ferran, M. C. & McBride, A. A. (1998).** Transient viral DNA replication and repression of viral transcription are supported by the C-terminal domain of the bovine papillomavirus type 1 E1 protein. *Journal of Virology* **72**, 796–801.
- Giri, I. & Yaniv, M. (1988).** Structural and mutational analysis of the E2 trans-activating proteins of papillomaviruses reveals three distinct functional domains. *EMBO Journal* **7**, 2823–2829.
- Gorman, C. M., Moffat, L. F. & Howard, B. H. (1982).** Recombinant genomes which express chloramphenicol acetyltransferase in mammalian cells. *Molecular and Cellular Biology* **2**, 1044–1051.
- Hemstrom Nilsson, C., Bakos, E., Petry, K. U., Schneider, A. & Durst, M. (1996).** Promoter usage in the E7 ORF of HPV16 correlates with epithelial differentiation and is largely confined to low-grade genital neoplasia. *International Journal of Cancer* **65**, 6–12.
- Higgins, G. D., Uzelin, D. M., Phillips, G. E., McEvoy, P., Marin, R. & Burrell, C. J. (1992).** Transcription patterns of human papillomavirus type 16 in genital intraepithelial neoplasia: evidence for promoter usage within the E7 open reading frame during epithelial differentiation. *Journal of General Virology* **73**, 2047–2057.
- Johnsen, C. K., Stanley, M. & Norrild, B. (1995).** Analysis of human papillomavirus type 16 E5 oncogene expression in vitro and from bicistronic messenger RNAs. *Intervirology* **38**, 339–345.
- Lupetti, R., Mortarini, R., Panceri, P., Sensi, M. & Anichini, A. (1996).** Interaction with fibronectin regulates cytokine gene expression in human melanoma cells. *International Journal of Cancer* **66**, 110–116.
- McBride, A. A., Romanczuk, H. & Howley, P. M. (1991).** The papillomavirus E2 regulatory proteins. *Journal of Biological Chemistry* **266**, 18411–18414.
- Phelps, W. C. & Howley, P. M. (1987).** Transcriptional trans-activation by the human papillomavirus type 16 E2 gene product. *Journal of Virology* **61**, 1630–1638.
- Rohlf, M., Winkenbach, S., Meyer, S., Rupp, T. & Durst, M. (1991).** Viral transcription in human keratinocyte cell lines immortalized by human papillomavirus type-16. *Virology* **183**, 331–342.
- Romanczuk, H., Thierry, F. & Howley, P. M. (1990).** Mutational analysis of cis elements involved in E2 modulation of human papillomavirus type 16 P97 and type 18 P105 promoters. *Journal of Virology* **64**, 2849–2859.
- Shally, M., Alloul, N., Jackman, A., Muller, M., Gissmann, L. & Sherman, L. (1996).** The E6 variant proteins E6I–E6IV of human papillomavirus 16: expression in cell free systems and bacteria and study of their interaction with p53. *Virus Research* **42**, 81–96.

- Sherman, L. & Alloul, N. (1992). Human papillomavirus type 16 expresses a variety of alternatively spliced mRNAs putatively encoding the E2 protein. *Virology* **191**, 953–959.
- Sherman, L. & Schlegel, R. (1996). Serum- and calcium-induced differentiation of human keratinocytes is inhibited by the E6 oncoprotein of human papillomavirus type 16. *Journal of Virology* **70**, 3269–3279.
- Sherman, L., Alloul, N., Golan, I., Durst, M. & Baram, A. (1992). Expression and splicing patterns of human papillomavirus type-16 mRNAs in pre-cancerous lesions and carcinomas of the cervix, in human keratinocytes immortalized by HPV 16, and in cell lines established from cervical cancers. *International Journal of Cancer* **50**, 356–364.
- Sherman, L., Jackman, A., Itzhaki, H., Conrad Stoppler, M., Koval, D. & Schlegel, R. (1997). Inhibition of serum- and calcium-induced differentiation of human keratinocytes by HPV16 E6 oncoprotein: role of p53 inactivation. *Virology* **237**, 296–306.
- Shirasawa, H., Tomita, Y., Kubota, K., Kasai, T., Sekiya, S., Takamizawa, H. & Simizu, B. (1988). Transcriptional differences of the human papillomavirus type 16 genome between precancerous lesions and invasive carcinomas. *Journal of Virology* **62**, 1022–1027.
- Shirasawa, H., Jin, M. H., Shimizu, K., Akutsu, N., Shino, Y. & Simizu, B. (1994). Transcription-modulatory activity of full-length E6 and E6^I proteins of human papillomavirus type 16. *Virology* **203**, 36–42.
- Smotkin, D. & Wettstein, F. O. (1986). Transcription of human papillomavirus type 16 early genes in a cervical cancer and a cancer-derived cell line and identification of the E7 protein. *Proceedings of the National Academy of Sciences, USA* **83**, 4680–4684.
- Smotkin, D., Prokoph, H. & Wettstein, F. O. (1989). Oncogenic and nononcogenic human genital papillomaviruses generate the E7 mRNA by different mechanisms. *Journal of Virology* **63**, 1441–1447.
- Steger, G. & Corbach, S. (1997). Dose-dependent regulation of the early promoter of human papillomavirus type 18 by the viral E2 protein. *Journal of Virology* **71**, 50–58.
- Stubenrauch, F. & Pfister, H. (1994). Low-affinity E2-binding site mediates downmodulation of E2 transactivation of the human papillomavirus type 8 late promoter. *Journal of Virology* **68**, 6959–6966.
- Stubenrauch, F., Leigh, I. M. & Pfister, H. (1996). E2 represses the late gene promoter of human papillomavirus type 8 at high concentrations by interfering with cellular factors. *Journal of Virology* **70**, 119–126.
- Tan, S. H., Gloss, B. & Bernard, H. U. (1992). During negative regulation of the human papillomavirus-16 E6 promoter, the viral E2 protein can displace Sp1 from a proximal promoter element. *Nucleic Acids Research* **20**, 251–256.
- Tan, S. H., Leong, L. E., Walker, P. A. & Bernard, H. U. (1994). The human papillomavirus type 16 E2 transcription factor binds with low cooperativity to two flanking sites and represses the E6 promoter through displacement of Sp1 and TFIID. *Journal of Virology* **68**, 6411–6420.
- Thierry, F. (1996). HPV proteins in the control of HPV transcription. In *Papillomavirus Reviews: Current Research on Papillomaviruses*, pp. 21–28. Edited by A. Lacey. Leeds: Leeds University Press.
- Ushikai, M., Lacey, M. J., Yamakawa, Y., Kono, M., Anson, J., Ishiji, T., Parkkinen, S., Wicker, P. N., Valentine, M.-E., Davidson, I., Turek, L. P. & Haugen, T. I. (1994). *trans* activation by the full-length E2 proteins of human papillomavirus type 16 and bovine papillomavirus type 1 *in vitro* and *in vivo*: cooperation with activation domains of cellular transcription factors. *Journal of Virology* **68**, 6655–6666.
- Zhao, Y., Wein, A. J. & Levin, R. M. (1995). Assessment of stress gene mRNAs (HSP-27, 60 and 70) in obstructed rabbit urinary bladder using a semi-quantitative RT-PCR method. *Molecular and Cellular Biochemistry* **148**, 1–7.
- zur Hausen, H. (1996). Papillomavirus infections – a major cause of human cancers. *Biochimica et Biophysica Acta* **1288**, F55–F78.

Received 9 March 1999; Accepted 30 April 1999