

Short Communication

Correspondence
Leslie Domier
l-domier@uiuc.edu

Received 16 August 2002
Accepted 30 October 2002

In vivo activity of *Rhopalosiphum padi* virus internal ribosome entry sites

Leslie L. Domier and Nancy K. McCoppin

United States Department of Agriculture, Agricultural Research Service, 1102 S. Goodwin Avenue, University of Illinois at Urbana/Champaign, Urbana, IL 61801, USA

The RNA genome of *Rhopalosiphum padi* virus (RhPV), like other members of the *Dicistroviridae*, contains two open reading frames that are preceded by internal ribosome entry sites (IRESs). To compare the activities of the two RhPV IRESs in insect cells, a system was established for the *in vivo* transcription and translation of plasmid templates containing the IRESs. In this system, the two RhPV IRESs directed initiation of translation from bicistronic plasmids with equal efficiency. Competition was observed between the two IRESs when they were *in cis* in a bicistronic plasmid. A mutation that disrupted the 3'-proximal pseudoknot of the intergenic (IG) IRES reduced translation initiation *in vivo*. Similarly, mutations in the RhPV IG IRES disrupted its ability to bind 80S particles *in vitro*. The two IRESs preferentially labelled proteins of different masses in UV cross-linking experiments, illustrating the different translation initiation mechanisms employed by the two elements.

Rhopalosiphum padi virus (RhPV) is an insect virus of the family *Dicistroviridae*, which includes *Acute bee paralysis virus*, *Black queen cell virus*, *Cricket paralysis virus* (CrPV), *Drosophila C virus*, *Himetobi P virus*, *Plautia stali intestine virus* (PSIV) and *Triatoma virus* (Mayo, 2002). The viruses in this family possess large messenger-sense, single-stranded RNA genomes and share physico-chemical properties with members of the *Picornaviridae*. However, rather than expressing single, large polyproteins with structural proteins located proximal to the amino termini, the RhPV genome contains two large open reading frames (ORFs) that express nonstructural and capsid polyproteins from 5'- and 3'-proximal ORFs, respectively (Moon *et al.*, 1998). Both ORFs are preceded by internal ribosome entry sites (IRESs) that are structurally and functionally different (Domier *et al.*, 2000; Kanamori & Nakashima, 2001; Wilson *et al.*, 2000b; Woolaway *et al.*, 2001). The RhPV 5' IRES is located upstream of the initiation codon of the first ORF and directs translation initiation at AUG codons in animal, insect and plant cell extracts (Woolaway *et al.*, 2001). The intergenic (IG) IRESs of RhPV and CrPV contain and direct translation initiation from CCU codons in the second ORF (Domier *et al.*, 2000; Wilson *et al.*, 2000b). Similarly, the IG IRES of PSIV initiates translation at a CUU codon (Sasaki & Nakashima, 1999). Many primary and secondary structural features of the IG IRESs of members of the *Dicistroviridae* are conserved, including three pseudoknots that are required for activity (Kanamori & Nakashima, 2001). The use of the noncanonical initiation codons is explained by the finding that the CrPV IG IRES initiates translation in a process that does not involve methionyl-tRNA and is independent of translation initiation factor eIF2 α (Wilson *et al.*, 2000a). In

addition, the activity of the CrPV IG IRES is stimulated by treatments that result in increased phosphorylation of eIF2 α (Fernandez *et al.*, 2002), conditions likely to occur late in virus infection due to the physiological stress of virus infection and/or the accumulation of virus-derived, double-stranded RNAs. The goal of these studies was to compare the *in vivo* activities of the two RhPV IRESs and to examine the effects of perturbations in the structure of the IG IRESs, including the 3'-proximal pseudoknot, on *in vivo* activity, initiation complex formation and protein binding.

To study the activity of the RhPV IRESs in insect cells, we established a system for the *in vivo* transcription and translation of DNA templates that used a recombinant baculovirus to express bacteriophage T7 RNA polymerase in *Spodoptera frugiperda* (Sf9) cells. Similar systems have been developed by others (van Poelwijk *et al.*, 1995; Yap *et al.*, 1997). For these studies, the bacteriophage T7 RNA polymerase gene was amplified from *Escherichia coli* JM109 DE3 DNA using oligonucleotide primers that added *Bam*HI and *Eco*RI recognition sites to the 5' and 3' ends of the gene, respectively. The resultant DNA was then digested with *Bam*HI/*Eco*RI, ligated into pFastBAC (Invitrogen) and recombined with the baculovirus, as recommended by the manufacturer. To test the ability of the baculovirus-expressed T7 RNA polymerase to transcribe a transfected plasmid template, 10⁶ Sf9 cells were infected with the recombinant baculovirus expressing T7 RNA polymerase at an m.o.i. of 100. After 24 h, the cells were transfected using Cellfectin reagent (Invitrogen) with 1 μ g plasmid DNA containing either the firefly or *Renilla* luciferase genes located downstream of the T7 promoter (Promega). Luciferase activities were determined 24 h after transfection and were about 1000- (firefly

luciferase) to 5000-fold (*Renilla* luciferase) higher than the negative controls (data not shown), as assayed using the Dual Luciferase Reporter Assay system (Promega) and a scintillation counter or Turner Designs TD-20/20 luminometer.

For comparison of the *in vivo* activities of wild-type and mutant RhPV IRESs, we constructed bicistronic plasmids containing the *Renilla* luciferase gene downstream of a T7 RNA polymerase promoter, followed by an RhPV IRES and the firefly luciferase gene (Fig. 1). The activities of the two enzymes were assayed as above. Each experiment (transfection and luciferase assay) was performed twice. *Renilla* luciferase was used as a transfection control by normalizing the activity of the linked firefly luciferase to that of *Renilla* luciferase. The bicistronic plasmid pRL17FL contained the RhPV IG IRES inserted between the *Renilla* and firefly luciferase genes. In this plasmid, the coding sequence of the firefly luciferase gene was fused in-frame with the ninth codon of RhPV ORF2 (Domier *et al.*, 2000). The firefly luciferase activity produced by pRL17FL was arbitrarily set to a value of 1.0 and all other firefly luciferase activities were expressed as a fraction of the pRL17FL firefly luciferase activity. As a negative control, the wild-type RhPV IG-IRES was replaced with a mutant IG IRES that contained two nucleotide substitutions that destabilized the 3' pseudoknot (mutation T21; Domier *et al.*, 2000) to make plasmid pRL21FL (Fig. 1). Transcripts containing this mutation failed to initiate translation of RhPV ORF2 in the rabbit reticulocyte lysate (RRL) *in vitro* translation system (Domier *et al.*, 2000). In extracts of Sf9 cells transfected with pRL17FL, the firefly luciferase activity was 36-fold higher than cells transfected with a plasmid containing only a T7 promoter and the *Renilla* luciferase gene and 4-fold higher than that produced by cells transfected with pRL21FL

(Fig. 1). These results showed that the RhPV IG IRES directed internal initiation in Sf9 cells. In addition, it confirmed the *in vitro* observations with RhPV and PSIV that showed that the 3' pseudoknot was required for IRES activity (Domier *et al.*, 2000; Kanamori & Nakashima, 2001).

To compare the abilities of the two RhPV IRESs to direct translation initiation *in vivo*, the IG IRES was removed from pRL17FL and replaced with the 5' IRES (nt 1–600) to make pRL5'FL. As with pRL17FL, the AUG initiation codon at position 580 of RhPV ORF1 was fused in-frame with the firefly luciferase gene sequence to maintain the environment in which the 5' IRES normally functions. The luciferase activities produced by pRL5'FL and pRL17FL were indistinguishable. This is in contrast with results reported for CrPV, where the IG IRES was more active than the 5' IRES *in vitro* (Wilson *et al.*, 2000b). It is possible that the relative activities of the two RhPV IRESs determined in this *in vivo* system may not reflect the activities of the IRESs in RhPV-infected aphids cells, since baculoviruses express antiapoptotic proteins (Clem *et al.*, 1991; Crook *et al.*, 1993) and, being DNA viruses, do not accumulate double-stranded RNA late in infection that could stimulate the activity of the IG IRES (Fernandez *et al.*, 2002). In addition, Woolaway *et al.* (2001) reported that the activity of the RhPV 5' IRES was increased when 100 nt, including the AUG initiation codon at position 580, were deleted from the 3' end of the 5' IRES. Hence, it is possible that a truncated 5' IRES might have a greater activity than the sequence used here.

To test for interactions between the two RhPV IRESs, the 5' IRES was inserted upstream of the *Renilla* luciferase in pRL17FL to make p5'RLIGFL, which mimicked the

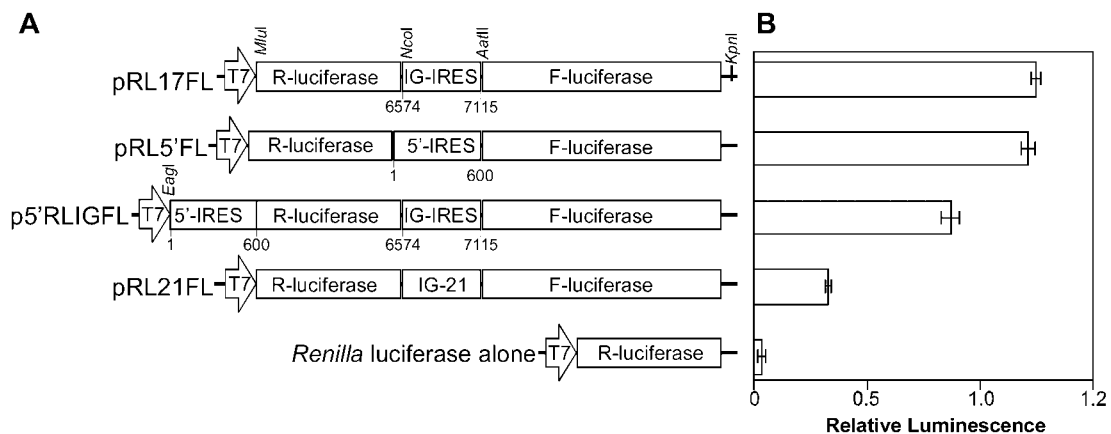

Fig. 1. *In vivo* activity of the RhPV IG IRES. (A) Maps of clones showing the positions of the RhPV IRESs and *Renilla* (R-luciferase) and firefly luciferase (F-luciferase) genes. Plasmid pRL21FL contained a mutated IG IRES (IG-21) inserted between the *Renilla* and firefly genes. Restriction enzyme sites introduced and used for cloning are indicated above the junctions of each segment. (B) Relative luminescence of extracts from Sf9 cells infected with a baculovirus expressing T7 RNA polymerase and transfected with the plasmid clones. *Renilla* luciferase was used as a transfection control by normalizing the activity of the linked firefly luciferase to that of *Renilla* luciferase. The activity of the firefly luciferase expressed by pRL17FL was arbitrarily set to a value of 1.0 and all other firefly luciferase activities were expressed as a fraction of the pRL17FL firefly luciferase activity. Each transfection was conducted twice. SEMs are indicated on each bar.

structure of the RhPV genome. In extracts of Sf9 cells transfected with p5'RLIGFL, the activity of firefly luciferase was about 70 % of the activity of pRL17FL. The reduced activity of the IG IRES when *in cis* with the 5' IRES could have resulted from competition between the two elements for ribosomal subunits or other translation initiation components. Similar inter-IRES competition was observed in bicistronic plasmids that contained the 5' IRESs of *Equine rhinitis B virus* and *Encephalomyocarditis virus* (Hinton & Crabb, 2001). Because of the stimulation of IG IRES activities of members of the *Dicistroviridae* by stresses that would probably inhibit translation from the 5' IRESs (Fernandez *et al.*, 2002), the competition, if it exists in RhPV-infected aphid cells, is likely to be relieved late in infection.

The interactions of the RhPV 5' and IG IRESs with RRL proteins were compared using *in vitro* transcripts labelled with [α - 33 P]UTP. Plasmids containing the RhPV 5' (nt 1–790) and IG (nt 6806–7283) IRESs were constructed, transcribed in the presence of [α - 33 P]UTP (Sambrook & Russell, 2000) and cross-linked to proteins by UV light (Niepmann *et al.*, 1997). Transcripts of the coding region of a modified green fluorescent protein (mGFP) (Haseloff *et al.*, 1997) were used as negative controls. The labelled RNAs were incubated for 10 min at 30 °C in 25 μ l RRL (Promega) supplemented with 110 mM KCl, 1.0 mM Mg $^{2+}$ and 4.0 mM guanylyl-imidodiphosphate (GMP–PNP), exposed to 254 nm UV light for 60 min on ice and degraded by the addition of RNase A (1 μ g ml $^{-1}$). Proteins were precipitated with trichloroacetic acid, solubilized in 6 M urea, run on SDS-polyacrylamide gels and visualized with a Molecular Dynamics Phosphorimager. In these experiments, the RhPV IG IRES preferentially labelled a protein of approximately 68 kDa (Fig. 2). The 5' IRES preferentially labelled protein bands of approximately 30 and 36 kDa more intensely than the other two RNAs. In addition, protein bands of 36, 44, 48 and 120 kDa were labelled by all three RNAs. The difference in labelling by the two RhPV IRESs likely reflects differences in the mechanisms by which they interact with host proteins in translation initiation. The identities of the proteins labelled by the RhPV IRESs remain to be determined. Since translation initiation from the CrPV IG IRES can occur in the absence of initiation factors (Wilson *et al.*, 2000a), the protein labelled by the RhPV IG IRES probably was not one of the initiation factors. The protein could represent double-stranded RNA-dependent protein kinase, PKR, which has an apparent mass of 68 kDa on SDS-polyacrylamide gels and is bound by RNAs of other viruses. For example, Epstein–Barr virus small RNA EBER-1 and adenovirus VA RNA1 specifically bind and inactivate PKR, thereby preventing the shutdown of translation in response to virus infection (Katze, 1995). It is also possible that the labelled proteins represent ribosomal proteins that come into close contact with the IRESs during translation initiation.

The abilities of wild-type and mutant forms of the RhPV IG IRES to enter into 80S initiation complexes were tested also.

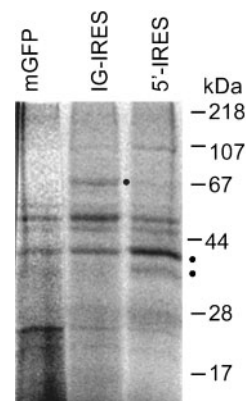

Fig. 2. Specific labelling of RRL proteins with ^{33}P -labelled RNAs. *In vitro* transcripts of the mGFP-coding region, RhPV IG and 5' IRESs were incubated with RRL in the presence of GMP–PNP, UV cross-linked, treated with RNase A, separated on SDS-polyacrylamide gels and exposed to a Phosphorimager screen. The RhPV 5' IRESs preferentially labelled proteins of approximately 30 and 36 kDa. The IG IRESs preferentially labelled a protein of approximately 68 kDa (indicated by dots next to the bands). The migrations of molecular mass standards are indicated at the right edge of the gel.

In vitro transcripts of the RhPV IG IRES were labelled with [α - 33 P]UTP as above, incubated with 25 μ l RRL for 10 min in the presence of 110 mM KCl, 1.0 mM Mg $^{2+}$ and 4.0 mM GMP–PNP, as described by Niepmann *et al.* (1997), and sedimented through 10–30 % sucrose gradients. The resulting gradient fractions were either counted with a scintillation counter or separated either on denaturing urea polyacrylamide or on 10 % SDS-polyacrylamide gels. Sucrose gradients of RRL incubated with wild-type RhPV IG IRES contained two radioactive peaks (Fig. 3). The radioactive peak at the top of the gradient contained short RNA species and unincorporated nucleotides (Fig. 3B). The peak that sedimented the fastest corresponded to 80S ribosomal subunits. Polyacrylamide gel analysis of sucrose gradient fractions showed that the peak that cosedimented with the 80S subunits contained intact RhPV IG IRES. The effects of deletions in stem-and-loop (SL) structures 1 and 2 (D6, D7 and T8, Fig. 3A; Domier *et al.*, 2000) on 80S complex formation were evaluated also. Like intact RhPV IG IRES, deletion mutant D6, which lacked the first SL, formed normal levels of 80S complexes. However, mutants D7 and T8, which lacked all of SL1 and large portions of SL2, failed to form 80S initiation complexes (Fig. 3C). SL2 contains sequences conserved among members of the *Dicistroviridae* and a portion of one of the three predicted RhPV pseudo-knots. Hence, deletions D7 and T8 could dramatically change the structure of the RhPV IG IRES. Hence, these studies also indicated that SL1 is not required for 80S preinitiation complex formation but that intact SL2 is required. These results are similar to those reported from *in vitro* studies with RhPV and PSIV (Domier *et al.*, 2000; Kanamori & Nakashima, 2001).

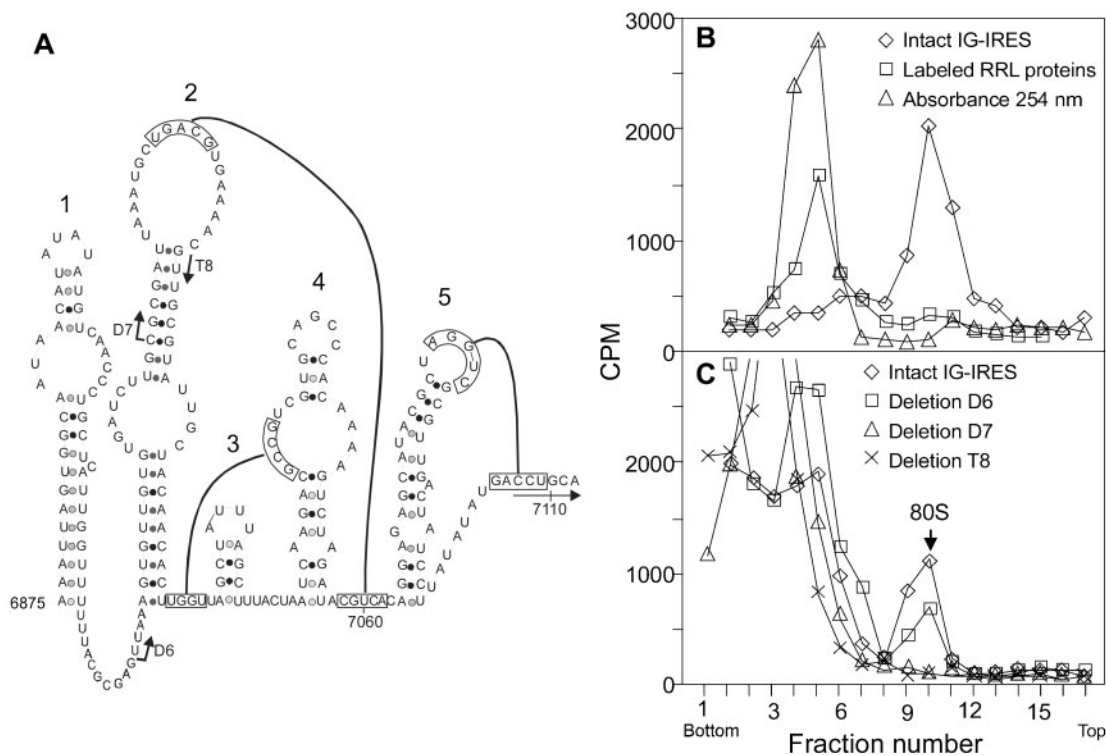

Fig. 3. Formation of 80S initiation complexes containing RhPV IG IRES in RRL. (A) Predicted secondary structures of the RhPV IG IRES. Base-pairing in the three predicted pseudoknots is indicated by lines connecting boxed nucleotides. The first two codons of ORF2 are underlined. The positions of the 5' termini of the transcripts produced by deletion mutations, D6 (nt 6930), D7 (nt 6951) and T8 (nt 6975) are indicated with arrows. Mutant D6 contained SLs 2–5 and all three predicted pseudoknots. Mutants D7 and T8 contained all of SLs 3–5 but only portions of SL2 at their 5' termini. T8 disrupted one of the predicted pseudoknots. *In vitro* transcripts of the RhPV IG IRES were labelled with [α - 32 P]UTP, incubated with RRL, cross-linked with UV light and sedimented through sucrose gradients. Sucrose gradient fractions were either (B) run on polyacrylamide gels or (C) counted directly. Most of the intact RhPV IG IRES was associated with 80S complexes (B). Intact and deletion mutant D6, which removes SL1 formed 80S complexes, whereas mutant transcripts D7 and T8, which lacked portions of SL2, failed to form 80S complexes (C).

From these studies we conclude that the RhPV IG IRES initiated translation with efficiencies comparable to that of the 5' IRES and that the IG IRES was not dependent on the presence of the 5' IRES. We also showed that RhPV 5' and IG IRESs preferentially labelled unique proteins – the identities of which remain to be determined. Finally, we showed that the mutations that disrupt the predicted secondary structures of the RhPV IG IRES reduced the *in vitro* and *in vivo* activities of the element, which is reflected in diminished interaction with 80S initiation complexes.

ACKNOWLEDGEMENTS

This work was supported by the United States Department of Agriculture – Agricultural Research Service. Mention of a trademark, proprietary product or vendor does not constitute a guarantee or warranty of the product by the USDA or the University of Illinois and does not imply its approval to the exclusion of other products or vendors that may also be suitable.

REFERENCES

- Clem, R. J., Fechheimer, M. & Miller, L. K. (1991). Prevention of apoptosis by a baculovirus gene during infection of insect cells. *Science* **254**, 1388–1390.
- Crook, N. E., Clem, R. J. & Miller, L. K. (1993). An apoptosis-inhibiting baculovirus gene with a zinc finger-like motif. *J Virol* **67**, 2168–2174.
- Domier, L. L., McCoppin, N. K. & D'Arcy, C. J. (2000). Sequence requirements for translation initiation of *Rhopalosiphum padi* virus ORF2. *Virology* **268**, 264–271.
- Fernandez, J., Yaman, I., Merrick, W. C., Koromilas, A., Wek, R. C., Sood, R., Hensold, J. & Hatzoglou, M. (2002). Regulation of internal ribosome entry site-mediated translation by eukaryotic initiation factor-2 α phosphorylation and translation of a small upstream open reading frame. *J Biol Chem* **277**, 2050–2058.
- Haseloff, J., Siemering, K. R., Prasher, D. C. & Hodge, S. (1997). Removal of a cryptic intron and subcellular localization of green fluorescent protein are required to mark transgenic *Arabidopsis* plants brightly. *Proc Natl Acad Sci U S A* **94**, 2122–2127.
- Hinton, T. M. & Crabb, B. S. (2001). The novel picornavirus *Equine rhinitis B virus* contains a strong type II internal ribosomal entry site

which functions similarly to that of *Encephalomyocarditis virus*. *J Gen Virol* **82**, 2257–2269.

Kanamori, Y. & Nakashima, N. (2001). A tertiary structure model of the internal ribosome entry site (IRES) for methionine-independent initiation of translation. *RNA* **7**, 266–274.

Katze, M. G. (1995). Regulation of the interferon-induced PKR: can viruses cope? *Trends Microbiol* **3**, 75–78.

Mayo, M. A. (2002). Virus taxonomy – Houston 2002. *Arch Virol* **147**, 1071–1076.

Moon, J. S., Domier, L. L., McCoppin, N. K., D'Arcy, C. J. & Jin, H. (1998). Nucleotide sequence analysis shows that *Rhopalosiphum padi virus* is a member of a novel group of insect-infecting RNA viruses. *Virology* **243**, 54–65.

Niepmann, M., Petersen, A., Meyer, K. & Beck, E. (1997). Functional involvement of polypyrimidine tract-binding protein in translation initiation complexes with the internal ribosome entry site of foot-and-mouth disease virus. *J Virol* **71**, 8330–8339.

Sambrook, J. & Russell, D. (2000). *Molecular Cloning: a Laboratory Manual*, 3rd edn, pp. 2100. Cold Spring Harbor, NY: Cold Spring Harbor Laboratory Press.

Sasaki, J. & Nakashima, N. (1999). Translation initiation at the CUU codon is mediated by the internal ribosome entry site of an insect picorna-like virus *in vitro*. *J Virol* **73**, 1219–1226.

van Poelwijk, F., Broer, R., Belsham, G. J., Oudshoorn, P., Vlak, J. M. & Goldbach, R. W. (1995). A hybrid baculovirus-bacteriophage T7 transient expression system. *Biotechnology* **13**, 261–264.

Wilson, J. E., Pestova, T. V., Hellen, C. U. & Sarnow, P. (2000a). Initiation of protein synthesis from the A site of the ribosome. *Cell* **102**, 511–520.

Wilson, J. E., Powell, M. J., Hoover, S. E. & Sarnow, P. (2000b). Naturally occurring dicistronic cricket paralysis virus RNA is regulated by two internal ribosome entry sites. *Mol Cell Biol* **20**, 4990–4999.

Woolaway, K. E., Lazaridis, K., Belsham, G. J., Carter, M. J. & Roberts, L. O. (2001). The 5' untranslated region of *Rhopalosiphum padi virus* contains an internal ribosome entry site which functions efficiently in mammalian, plant, and insect translation systems. *J Virol* **75**, 10244–10249.

Yap, C. C., Ishii, K., Aoki, Y., Aizaki, H., Tani, H., Shimizu, H., Ueno, Y., Miyamura, T. & Matsuura, Y. (1997). A hybrid baculovirus-T7 RNA polymerase system for recovery of an infectious virus from cDNA. *Virology* **213**, 192–200.